

XFU400 Miniature Load Cell



- 0-500N to 0-5kN [100Lbf to 1kLbf]
- Tension and/or Compression
- Spherical Plain Rod-End Bearings
- Excellent Accuracy
- For Static and Dynamic Applications

DESCRIPTION

Available in a range of measurements and a variety of mounting threads, the XFU400 is easily installed. Its miniature size facilitates testing where space is at a premium. The sensing element is fitted with a fully temperature compensated Wheatstone bridge equipped with high stability micro-machined silicon strain gages. The XFU400 is used in applications that require a spherical plain rod-end bearing and has the capacity of accepting a full scale range of up to 5 kN [1 kLbf].

With many years of experience as a designer and manufacturer of sensors, Measurement Specialties, Inc. often works with customers to design or customize sensors for specific uses and testing environments.

To meet your needs we also offer complete turnkey systems. The matched components (sensor, power, amplifier and digital display) are formatted, calibrated and ready for immediate use.

FEATURES

- Based on standard rod end bearings
- Low deflection
- Easy to integrate
- Fast response time
- For Static and Dynamic Applications

APPLICATIONS

- Linkage forces
- Machine tool
- Automotive systems test
- Robotics and effectors

STANDARD RANGES

F.S. Ranges in N	500	1k	3k	4k	5k
F.S. Ranges in Lbf	100	200	600	800	1k
Stiffness in N/m	3.4×10^8	5.5×10^8	1.2×10^9	1.4×10^9	1.9×10^9
Stiffness in Lbf/ft	2.3×10^7	3.8×10^7	8.2×10^7	9.6×10^7	1.3×10^8

XFU400 Miniature Load Cell

PERFORMANCE SPECIFICATIONS

Ambient Temperature: 20±1° C (unless otherwise specified)

PARAMETERS	
Operating Temperature Range (OTR)	-40 to 120 °C [-40 to 248 °F]
Compensated Temperature Range (CTR)	0 to 60 °C [32 to 140 °F]
Zero Shift in CTR	<2% F.S. / 50 °C [100 °F]
Sensitivity Shift in CTR	<2% of reading / °C [2 °F]
Range (F.S.)	0-500N to 0-5kN [0-100Lbf to 0-1kLbf]
Over-Range	
Without Damage	1.5 x F.S.
Without Destruction	2 x F.S.
Accuracy	
Linearity	≤±0.3% F.S
Hysteresis	≤±0.2% F.S

Electrical Characteristics

Model	XFU400
Supply Outage	10Vdc
F.S. Output	10mV/V
Zero Offset	<±10 mV
Input Impedance/Consumption	1000 to 3000Ω
Output Impedance	500 to 1000Ω
Insulation under 50Vdc	≥100MΩ

Notes

1. Shielded cable with 4 Teflon wires (AWG36/28), standard length 2 m [6.5 ft] with strain relief spring
2. Material: Body in zinc coated and passivated steel
3. Protection Index: IP50 (other levels available on request)

XFU400 Miniature Load Cell

DIMENSIONS & WIRING SCHEMATIC (IN METRIC AND IMPERIAL)

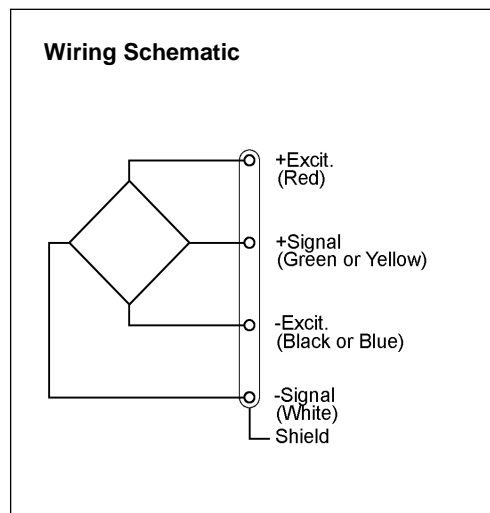
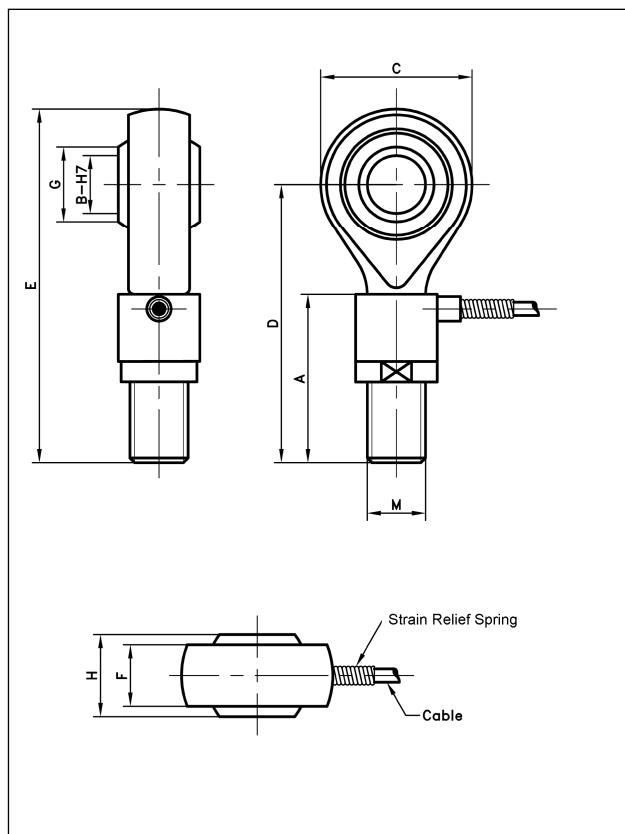

Dimensions in mm [inch]

Full Scale Range in N [in Lbf]	500 [100]	1000 [200]	3000 [600]	4k [800]	5k [1k]
Threading	M4	M5	M8	M10	M12
A	18 [0.71]	20 [0.79]	25 [0.98]	29 [1.14]	33 [1.3]
B	4 [0.16]	5 [0.2]	8 [0.31]	10 [0.39]	12 [0.47]
C	14 [0.55]	16 [0.63]	22 [0.87]	26 [1.02]	30 [1.18]
D	30 [1.18]	33 [1.3]	42 [1.65]	48 [1.89]	54 [2.13]
E	37 [1.46]	41 [1.61]	53 [2.09]	61 [2.4]	69 [2.72]
F	2.25 [0.089]	6 [0.24]	9 [0.35]	10.5 [0.41]	12 [0.47]
G	6.46 [0.25]	7.71 [0.3]	10.4 [0.41]	12.92 [0.51]	15.43 [0.61]
H	7 [0.28]	8 [0.31]	12 [0.47]	14 [0.55]	16 [0.63]
Stiffness in N/m	3.4x10 ⁸	5.5x10 ⁸	1.2x10 ⁹	1.4x10 ⁹	1.9x10 ⁹
Stiffness in Lbf/ft	2.3x10 ⁷	3.8x10 ⁷	8.2x10 ⁷	9.6x10 ⁷	1.3x10 ⁸



XFU400 Miniature Load Cell

OPTIONS

ET1 : CTR -20 to 100 °C [-4 to 212 °F]
LC“x” : Additional cable length to standard length (in m) (Note : “X” = Custom value)

ORDERING INFO

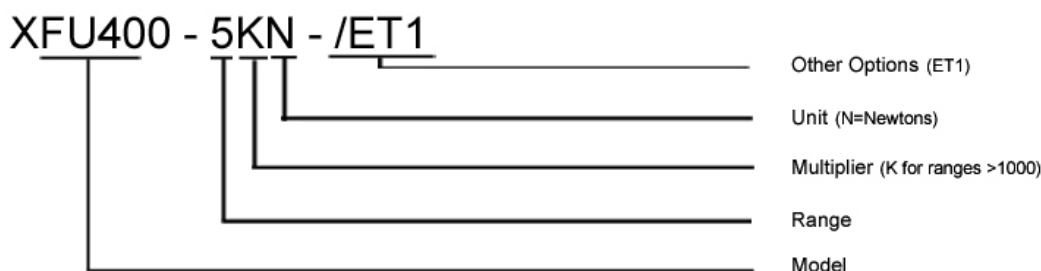

NORTH AMERICA

Measurement Specialties
 45738 Northport Loop West
 Fremont, CA 94538
 USA
 Tel: 1-800-767-1888
 Fax: 1-510-498-1578
pfg.cs.amer@meas-spec.com

EUROPE

Measurement Specialties
 (Europe), Ltd.
 26 Rue des Dames
 78340 Les Clayes-sous-Bois,
 France
 Tel: +33 (0) 130 79 33 00
 Fax: +33 (0) 134 81 03 59
pfg.cs.emea@meas-spec.com

ASIA

Measurement Specialties
 (China), Ltd.
 No. 26 Langshan Road
 Shenzhen High-Tech Park (North)
 Nanshan District, Shenzhen
 518107
 China
 Tel: +86 755 3330 5088
 Fax: +86 755 3330 5099
pfg.cs.asia@meas-spec.com

The information in this sheet has been carefully reviewed and is believed to be accurate; however, no responsibility is assumed for inaccuracies. Furthermore, this information does not convey to the purchaser of such devices any license under the patent rights to the manufacturer. Measurement Specialties, Inc. reserves the right to make changes without further notice to any product herein. Measurement Specialties, Inc. makes no warranty, representation or guarantee regarding the suitability of its product for any particular purpose, nor does Measurement Specialties, Inc. assume any liability arising out of the application or use of any product or circuit and specifically disclaims any and all liability, including without limitation consequential or incidental damages. Typical parameters can and do vary in different applications. All operating parameters must be validated for each customer application by customer's technical experts. Measurement Specialties, Inc. does not convey any license under its patent rights nor the rights of others.