



100kHz to 1GHz RF Power Detector

May 2002

FEATURES

- Temperature Compensated Internal Schottky Diode RF Detector
- Wide Input Power Range: -34dBm to 14dBm
- Ultra Wide Input Frequency Range: 100kHz to 1000MHz
- Buffered Output
- Wide V_{CC} Range of 2.7V to 6V
- Low Operating Current: $550\mu\text{A}$
- Low Shutdown Current: $<2\mu\text{A}$
- Low Profile (1mm) ThinSOT™ Package

APPLICATIONS

- Wireless Transceivers
- Wireless and Cable Infrastructure
- RF Power Alarm
- Envelope Detector

DESCRIPTION

The LTC[®]5507 is an RF power detector for applications operating from 100kHz to 1000MHz . The input frequency range is determined by an external capacitor. A temperature-compensated Schottky diode peak detector and buffer amplifier are combined in a small 6-pin ThinSOT package.

The RF input voltage is peak detected using an on-chip Schottky diode and external capacitor. The detected voltage is buffered and supplied to the V_{OUT} pin. A power saving shutdown mode reduces supply current to less than $2\mu\text{A}$.

LTC, LTC and LT are registered trademarks of Linear Technology Corporation.
ThinSOT is a trademark of Linear Technology Corporation

TYPICAL APPLICATION

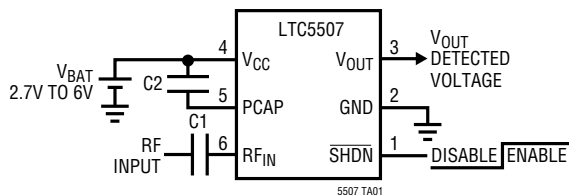
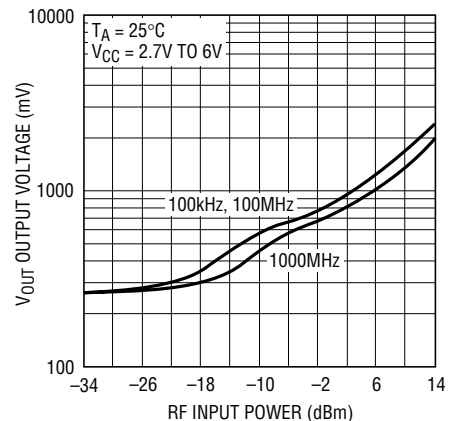

Figure 1. 100kHz to 1000MHz RF Power Detector

Typical Detector Characteristics at 100kHz , 100MHz and 1000MHz



5507 TA01b

LTC5507

ABSOLUTE MAXIMUM RATINGS

(Note 1)

V_{CC} , V_{OUT} to GND	-0.3V to 6.5V
RF_{IN} Voltage to GND	$(V_{CC} - 1.8V)$ to 7V
\overline{SHDN} Voltage to GND	-0.3V to $(V_{CC} + 0.3V)$
PCAP Voltage to GND	$(V_{CC} - 1.8V)$ to 7V
I_{VOUT}	5mA
Operating Temperature Range (Note 2) ..	-40°C to 85°C
Maximum Junction Temperature	125°C
Storage Temperature Range	-65°C to 150°C
Lead Temperature (Soldering, 10 sec).....	300°C

PACKAGE/ORDER INFORMATION

	ORDER PART NUMBER
	LTC5507ES6
	S6 PART MARKING
	LTZX

Consult LTC Marketing for parts specified with wider operating temperature ranges.

ELECTRICAL CHARACTERISTICS

The ● denotes the specifications which apply over the full operating temperature range, otherwise specifications are at $T_A = 25^\circ\text{C}$. $V_{CC} = 3.6\text{V}$, RF Input Signal is Off, unless otherwise noted.

PARAMETER	CONDITIONS	MIN	TYP	MAX	UNITS
V_{CC} Operating Voltage		● 2.7		6	V
I_{VCC} Shutdown Current	$\overline{SHDN} = 0V$	●		2	μA
I_{VCC} Operating Current	$\overline{SHDN} = V_{CC}$, $I_{VOUT} = 0\text{mA}$	●	0.55	0.85	mA
V_{OUT} V_{OL} (No RF Input)	$R_{LOAD} = 2k$, $\overline{SHDN} = V_{CC}$, Enabled $\overline{SHDN} = 0V$, Disabled	130	250 1	370	mV mV
V_{OUT} Output Current	$V_{OUT} = 1.75V$, $V_{CC} = 2.7V$ to 6V, $\Delta V_{OUT} = 10\text{mV}$	● 1	2		mA
V_{OUT} Enable Time	$\overline{SHDN} = V_{CC}$, $C_{LOAD} = 33\text{pF}$, $R_{LOAD} = 2k$	●	7	20	μs
V_{OUT} Load Capacitance	(Note 4)	●		33	pF
V_{OUT} Noise	$V_{CC} = 3V$, Noise BW = 1.5MHz, 50 Ω RF Input Termination		2		mV _{p-p}
\overline{SHDN} Voltage, Chip Disabled	$V_{CC} = 2.7V$ to 6V	●		0.35	V
\overline{SHDN} Voltage, Chip Enabled	$V_{CC} = 2.7V$ to 6V	● 1.4			V
\overline{SHDN} Input Current	$\overline{SHDN} = 3.6V$	●	24	40	μA
RF_{IN} Input Frequency Range			0.1–1000		MHz
Max RF_{IN} Input Power	(Note 3)		14		dBm
RF_{IN} AC Input Resistance	$F = 10\text{MHz}$, RF Input = -10dBm $F = 1000\text{MHz}$, RF Input = -10dBm		130 95		Ω Ω
RF_{IN} Input Shunt Capacitance			1.7		pF

Note 1: Absolute Maximum Ratings are those values beyond which the life of a device may be impaired.

Note 2: Specifications over the -40°C to 85°C operating temperature range are assured by design, characterization and correlation with statistical process controls.

Note 3: RF performance is tested at: 80MHz, -4dBm

Note 4: Guaranteed by design.

TYPICAL PERFORMANCE CHARACTERISTICS

LTC5507 Typical Detector Characteristics, 100kHz, $V_{CC} = 2.7V$ TO $6V$

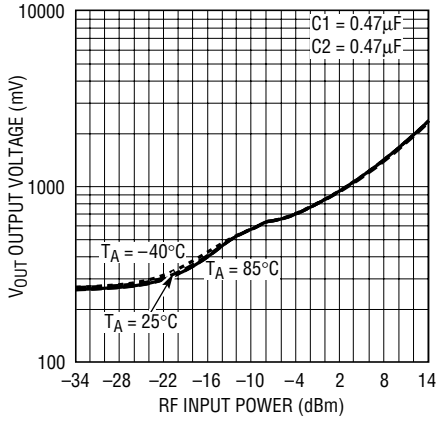

5507 G01

LTC5507 Typical Detector Characteristics, 100MHz, $V_{CC} = 2.7V$ TO $6V$

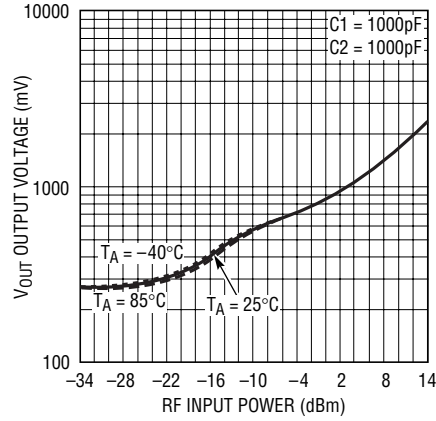

5507 G02

LTC5507 Typical Detector Characteristics, 1000MHz, $V_{CC} = 2.7V$ TO $6V$

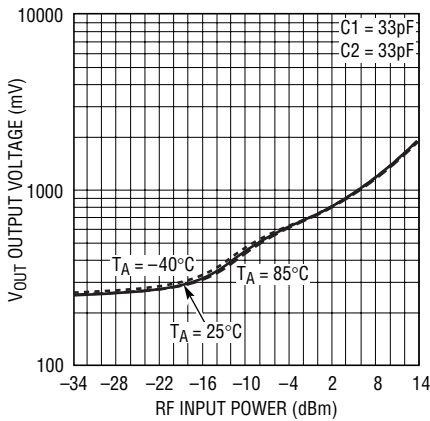

5507 G03

Positive V_{OUT} Slew Rate vs $C2$ Capacitance

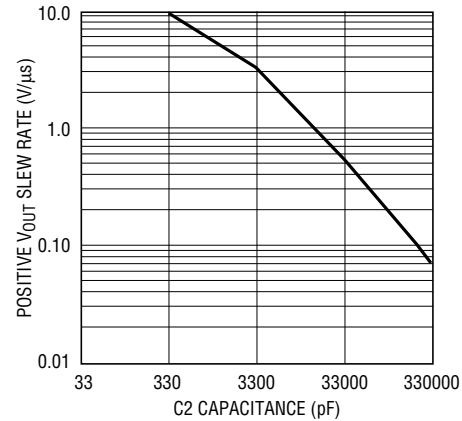

5507 G04

Negative V_{OUT} Slew Rate vs $C2$ Capacitance

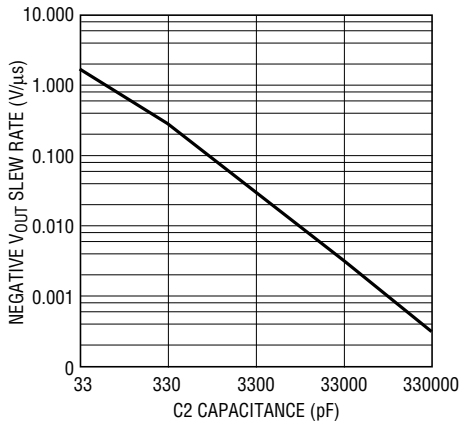

5507 G05

V_{OUT} BW vs $C2$ Capacitance

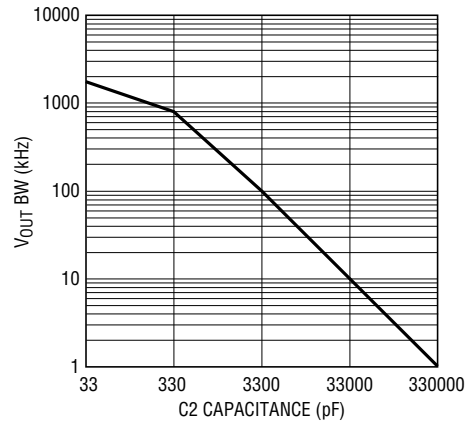

5507 G06

5507I

LTC5507

PIN FUNCTIONS

SHDN (Pin 1): Shutdown Input. A logic low or no-connect on the SHDN pin places the part in shutdown mode. A logic high enables the part. SHDN has an internal 150k pull down resistor to ensure that the part is in shutdown when the enable driver is in a tri-state condition.

GND (Pin 2): System Ground.

V_{OUT} (Pin 3): Buffered and Level Shifted Detector Output Voltage.

V_{CC} (Pin 4): Power Supply Voltage, 2.7V to 6V. V_{CC} should be bypassed with 0.1μF and 100pF ceramic capacitors.

PCAP (Pin 5): Peak Detector Hold Capacitor. Capacitor value is dependent on RF frequency. Capacitor must be connected between PCAP and V_{CC}.

RF_{IN} (Pin 6): RF Input Voltage. Referenced to V_{CC}. A coupling capacitor must be used to connect to the RF signal source. The frequency range is 100kHz to 1000MHz. This pin has an internal 250Ω termination and an internal Schottky diode detector.

BLOCK DIAGRAM

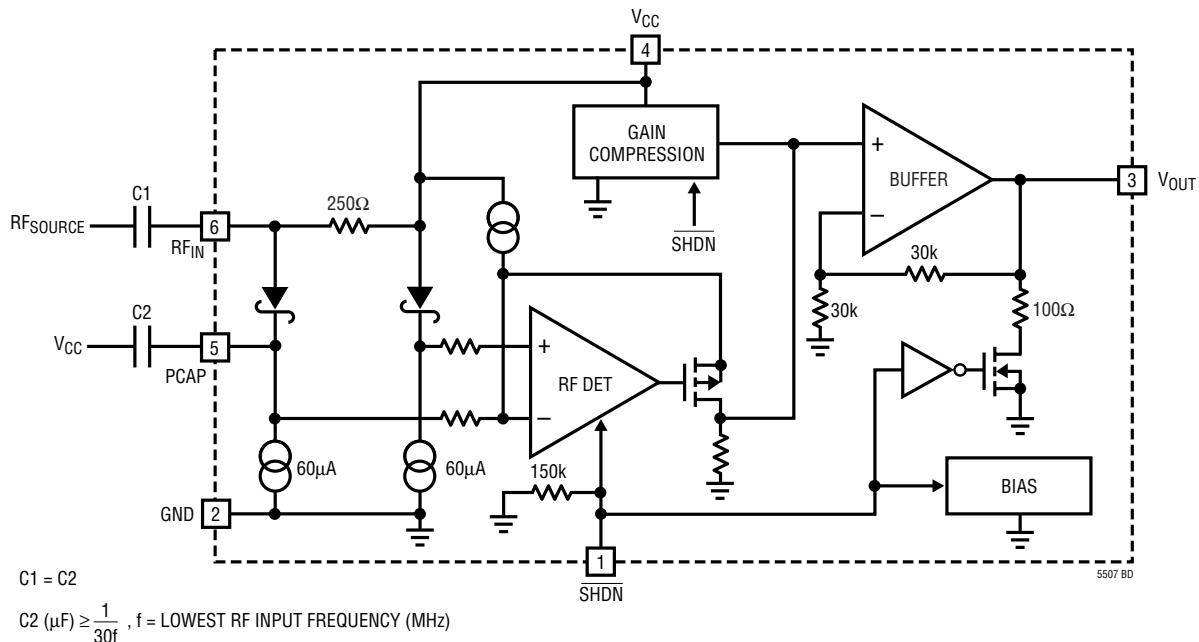

Figure 2.

APPLICATIONS INFORMATION

Operation

The LTC5507 integrates several functions to provide RF power detection over frequencies up to 1000MHz. These functions include an internally compensated buffer amplifier, an RF Schottky diode peak detector and level shift amplifier to convert the RF signal to DC, a delay circuit to avoid voltage transients at V_{OUT} when coming out of shut-down, and a gain compression circuit to extend the detector dynamic range.

Buffer Amplifier

The buffer amplifier has a gain of two and is capable of driving a 2mA load. The buffer amplifier typically has an output voltage range of 0.25V to $V_{CC} - 0.1V$.

RF Detector

The internal RF Schottky diode peak detector and level shift amplifier converts the RF input signal to a low frequency signal. The frequency range of the RF pin is typically up to 1000MHz. The detector demonstrates excellent operation over a wide range of input power. The Schottky detector is biased at about 70 μ A. The hold capacitor is external.

Gain Compression

The gain compression circuit changes the feedback ratio as the RF peak-detected input voltage increases above 60mV. Below 60mV, the DC voltage gain from the peak detector to the buffer output is 4. Above 140mV, the DC voltage gain is reduced to 0.75. The compression expands the low power detector range due to higher gain.

Modes of Operation

MODE	$\overline{\text{SHDN}}$	OPERATION
Shutdown	Low	Disabled
Enable	High	Power Detect

Applications

The LTC5507 can be used as a self-standing signal strength measuring receiver for a wide range of input signals from -34dBm to 14dBm for frequencies up to 1000MHz.

The LTC5507 can be used as a demodulator for AM and ASK modulated signals with data rates up to 1.5MHz. Depending on specific application needs, the RSSI output can be split into two branches, providing AC-coupled data (or audio) output and DC-coupled, RSSI output for signal strength measurements and AGC.

C1, C2 Capacitor Selection (Refer to Figure 3)

C1 couples the RF input signal to the detector input RF_{IN} which is referenced to V_{CC} . C2 is the peak detector capacitor connected between PCAP and V_{CC} . The value of C2 will affect the slew rate and bandwidth. Typically C1 can equal C2. Ceramic capacitors are recommended for C1 and C2. The values for C1 and C2 are dependent on the operating RF frequency. The capacitive reactance should be less than 5 Ω to minimize ripple on C2.

$$C2(\mu\text{F}) \geq 1/(30 \cdot f) \text{ where } f \text{ is the lowest RF input frequency (MHz)}$$

$$C1 = C2$$

In general, select C1 and C2 large enough to pass the lowest expected RF signal frequency, as described by the above formulas. But optimize C1 and C2, subject to this constraint, to improve output slew rate and bandwidth, and to enable good AC performance for the highest expected RF signal frequency.

LTC5507

APPLICATIONS INFORMATION

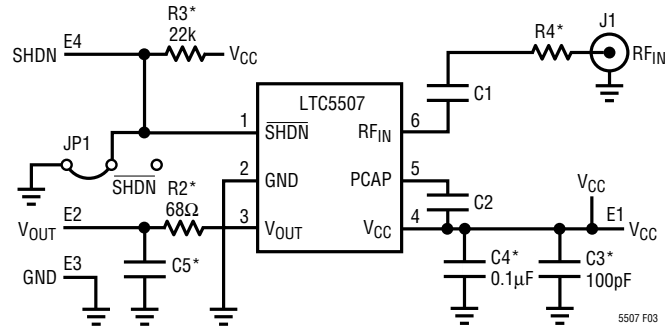

* OPTIONAL COMPONENTS
 R2 AND C5 FORM AN OPTIONAL OUTPUT LOWPASS FILTER.
 R3 IS USED FOR DEMO PURPOSES ONLY, AND IS NOT USED IN ACTUAL PRODUCT IMPLEMENTATION.
 R4 CAN BE USED FOR INPUT POWER LIMITING OR BROADBAND IMPEDANCE MATCHING.
 C3 AND C4 ARE OPTIONAL POWER SUPPLY FILTERS.

Figure 3. Evaluation Demo Board Schematic

PACKAGE DESCRIPTION

S6 Package
6-Lead Plastic TSOT-23
 (Reference LTC DWG # 05-08-1636)

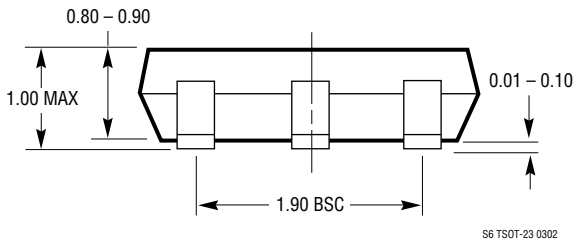
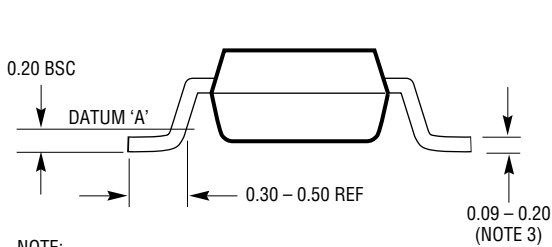
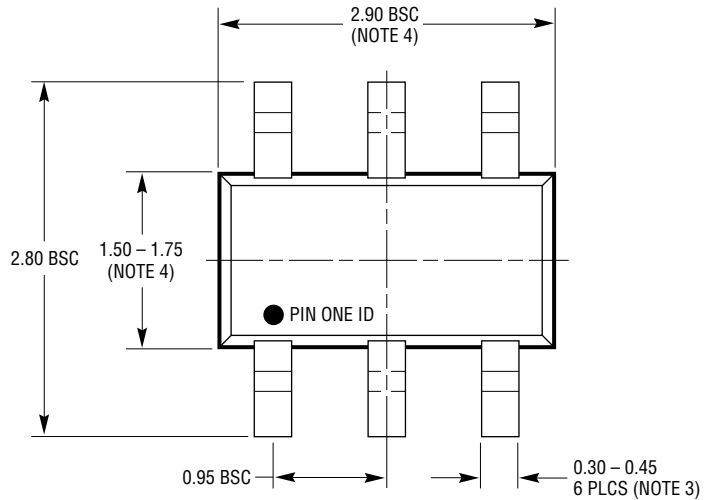
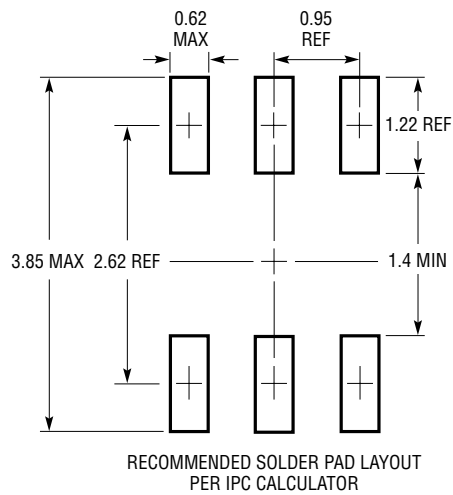

- NOTE:
1. DIMENSIONS ARE IN MILLIMETERS
 2. DRAWING NOT TO SCALE
 3. DIMENSIONS ARE INCLUSIVE OF PLATING
 4. DIMENSIONS ARE EXCLUSIVE OF MOLD FLASH AND METAL BURR
 5. MOLD FLASH SHALL NOT EXCEED 0.254mm
 6. JEDEC PACKAGE REFERENCE IS MO-193

S6 TSOT-23 0302

LTC5507

RELATED PARTS

PART NUMBER	DESCRIPTION	COMMENTS
RF Power Controllers		
LTC1757A	RF Power Controller	Single/Dual Band GSM/DCS/GPRS Mobile Phones
LTC1758	RF Power Controller	Single/Dual Band GSM/DCS/GPRS Mobile Phones
LTC1957	RF Power Controller	Single/Dual Band GSM/DCS/GPRS Mobile Phones
LTC4400	ThinSOT RF PA Controller	Single/Dual Band GSM/DCS/GPRS Phones, 45dB Dynamic Range, 450kHz Loop BW
LTC4401	ThinSOT RF PA Controller	Single/Dual Band GSM/DCS/GPRS Phones, 45dB Dynamic Range, 250kHz Loop BW
LT5504	800MHz to 2.7GHz RF Measuring Receivers	80dB Dynamic Range
LTC5505	ThinSOT RF Power Detector	300MHz to 3GHz RF Power Detector
Other Related Parts		
LTC1503	Inductorless Step-Down DC/DC Converter	600kHz, Up to 100mA, 25% Higher Efficiency than Linear Regulator
LTC1555L-1.8	SIM Power Supply and Level Translator	Generates 1.8V, 3V or 5V; >10kV ESD on All SIM Contact Pins
LT [®] 1615	Step-Up DC/DC Converter	ThinSOT, Low 20 μ A Quiescent Current, V_{IN} as Low as 1V, 300mA I_{OUT}
LT1617	Inverting DC/DC Converter	ThinSOT, Low 20 μ A Quiescent Current, V_{IN} as Low as 1V, 300mA I_{OUT}
LTC1682	Low Noise Charge Pump with LDO	60 μ V _{RMS} Output Noise, Small MSOP Package
LTC1734	ThinSOT Li-Ion Battery Charger	Only Two External Components, Charge Current Indicator, up to 700mA
LT1761	Low Dropout, Low Noise Linear Regulator	ThinSOT, 300mV Dropout at 100mA, 20 μ V _{RMS} Output Noise (10Hz to 100kHz)
LTC1878	Step-Down DC/DC Converter	Integrated Synchronous Operation, Up to 95% Efficiency, 1A Switch Current
LTC1928	Low Noise Charge Pump	ThinSOT, 90 μ V _{RMS} Output Noise (100kHz BW), I_{OUT} Up to 30mA
LT1932	White LED Driver	ThinSOT, 1.2MHz DC/DC Constant-Current LED Driver, Dimming Control
LT1944	Step-Up DC/DC Converter	Dual Output for LCD Bias, Low Quiescent Current of 20 μ A, $1.2V \leq V_{IN} \leq 15V$
LTC1986	SIM Power Supply	ThinSOT, 3V and 5V, Ultralow Supply Current of 14 μ A, <0.92cm ² PCB
LTC3200	Low Noise Charge Pump	2MHz Switching Frequency Allows Small Size Capacitors, I_{OUT} Up to 100mA
LTC3401	Step-Up DC/DC Converter	Synchronous Rectification, Up to 97% Efficiency, 1A Switch Current, 3MHz
LTC3402	Step-Up DC/DC Converter	Synchronous Rectification, Up to 97% Efficiency, 2A Switch Current, 3MHz
LTC3404	Step-Down DC/DC Converter	1.4MHz Synchronous Rectification, 10 μ A Quiescent Current
LT5511	High Signal Level Upconverting Mixer	10MHz to 3000MHz RF Output Range, Integrated LO Buffer, 17dBm IIP3

SUNSTAR商斯达实业集团是集研发、生产、工程、销售、代理经销、技术咨询、信息服务等为一体的高科技企业，是专业高科技电子产品生产厂家，是具有10多年历史的专业电子元器件供应商，是中国最早和最大的仓储式连锁规模经营大型综合电子零部件代理分销商之一，是一家专业代理和分销世界各大品牌IC芯片和电子元器件的连锁经营综合性国际公司。在香港、北京、深圳、上海、西安、成都等全国主要电子市场设有直属分公司和产品展示展销窗口门市部专卖店及代理分销商，已在全国范围内建成强大统一的供货和代理分销网络。我们专业代理经销、开发生产电子元器件、集成电路、传感器、微波光电元器件、工控机/DOC/DOM电子盘、专用电路、单片机开发、MCU/DSP/ARM/FPGA软件硬件、二极管、三极管、模块等，是您可靠的一站式现货配套供应商、方案提供商、部件功能模块开发配套商。专业以现代信息产业（计算机、通讯及传感器）三大支柱之一的传感器为主营业务，专业经营各类传感器的代理、销售生产、网络信息、科技图书资料及配套产品设计、工程开发。我们的专业网站——中国传感器科技信息网（全球传感器数据库）www.SENSOR-IC.COM 服务于全球高科技生产商及贸易商，为企业科技产品开发提供技术交流平台。欢迎各厂商互通有无、交换信息、交换链接、发布寻求代理信息。欢迎国外高科技传感器、变送器、执行器、自动控制产品厂商介绍产品到中国，共同开拓市场。本网站是关于各种传感器-变送器-仪器仪表及工业自动化大型专业网站，深入到工业控制、系统工程计 测量、自动化、安防报警、消费电子等众多领域，把最新的传感器-变送器-仪器仪表买卖信息，最新技术供求，最新采购商，行业动态，发展方向，最新的技术应用和市场资讯及时的传递给广大科技开发、科学研究、产品设计人员。本网站已成功为石油、化工、电力、医药、生物、航空、航天、国防、能源、冶金、电子、工业、农业、交通、汽车、矿山、煤炭、纺织、信息、通信、IT、安防、环保、印刷、科研、气象、仪器仪表等领域从事科学研究、产品设计、开发、生产制造的科技人员、管理人员、和采购人员提供满意服务。我们公司专业生产、代理、经销、销售各种传感器、变送器、敏感元器件、开关、执行器、仪器仪表、自动化控制系统：专门从事设计、生产、销售各种传感器、变送器、各种测控仪表、热工仪表、现场控制器、计算机控制系统、数据采集系统、各类环境监控系统、专用控制系统应用软件以及嵌入式系统开发及应用等工作。如热敏电阻、压敏电阻、温度传感器、温度变送器、湿度传感器、湿度变送器、气体传感器、气体变送器、压力传感器、压力变送、称重传感器、物（液）位传感器、物（液）位变送器、流量传感器、流量变送器、电流（压）传感器、溶氧传感器、霍尔传感器、图像传感器、超声波传感器、位移传感器、速度传感器、加速度传感器、扭距传感器、红外传感器、紫外传感器、火焰传感器、激光传感器、振动传感器、轴角传感器、光电传感器、接近传感器、干簧管传感器、继电器传感器、微型电泵、磁敏（阻）传感器、压力开关、接近开关、光电开关、色标传感器、光纤传感器、齿轮测速传感器、时间继电器、计数器、计米器、温控仪、固态继电器、调压模块、电磁铁、电压表、电流表等特殊传感器。同时承接传感器应用电路、产品设计和自动化工程项目。

更多产品请看本公司产品专用销售网站：

商斯达中国传感器科技信息网：<http://www.sensor-ic.com/>

商斯达工控安防网：<http://www.pc-ps.net/>

商斯达电子元器件网：<http://www.sunstare.com/>

商斯达微波光电产品网：[HTTP://www.rfoe.net/](http://www.rfoe.net/)

商斯达消费电子产品网：<http://www.icasic.com/>

商斯达军工产品网：<http://www.junpinic.com/>

商斯达实业科技产品网：<http://www.sunstars.cn/> 传感器销售热线：

地址：深圳市福田区福华路福庆街鸿图大厦1602室

电话：0755-83607652 83376489 83376549 83370250 83370251 82500323

传真：0755-83376182 (0) 13902971329 MSN: SUNS888@hotmail.com

邮编：518033 E-mail: szss20@163.com QQ: 195847376

深圳赛格展销部：深圳华强北路赛格电子市场2583号 电话：0755-83665529 25059422

技术支持：0755-83394033 13501568376

欢迎索取免费详细资料、设计指南和光盘；产品凡多，未能尽录，欢迎来电查询。

北京分公司：北京海淀区知春路132号中发电子大厦3097号

TEL: 010-81159046 82615020 13501189838 FAX: 010-62543996

上海分公司：上海市北京东路668号上海赛格电子市场D125号

TEL: 021-28311762 56703037 13701955389 FAX: 021-56703037

西安分公司：西安高新开发区20所(中国电子科技集团导航技术研究所)

西安劳动南路88号电子商城二楼D23号

TEL: 029-81022619 13072977981 FAX: 029-88789382