



# Precision Analog-to-Digital Converter (ADC) with 8051 Microcontroller and Flash Memory

## FEATURES

### ANALOG FEATURES

- 24-BITS NO MISSING CODES
- 22-BITS EFFECTIVE RESOLUTION AT 10Hz  
Low Noise: 75nV
- PGA FROM 1 TO 128
- PRECISION ON-CHIP VOLTAGE REFERENCE:  
Accuracy: 0.2%  
Drift: 5ppm/°C
- 8 DIFFERENTIAL/SINGLE-ENDED CHANNELS
- ON-CHIP OFFSET/GAIN CALIBRATION
- OFFSET DRIFT: 0.02PPM/°C
- GAIN DRIFT: 0.5PPM/°C
- BURN-OUT SENSOR DETECTION
- SINGLE-CYCLE CONVERSION
- SELECTABLE BUFFER INPUT

### DIGITAL FEATURES

#### Microcontroller Core

- 8051 COMPATIBLE
- HIGH SPEED CORE:  
4 Clocks per Instruction Cycle
- DC TO 33MHz
- SINGLE INSTRUCTION 121ns
- DUAL DATA POINTER

#### Memory

- UP TO 32kB FLASH DATA MEMORY
- FLASH MEMORY PARTITIONING
- ENDURANCE 1M ERASE/WRITE CYCLES,  
100 YEAR DATA RETENTION
- IN-SYSTEM SERIALLY PROGRAMMABLE
- EXTERNAL PROGRAM/DATA MEMORY (64kB)
- 1,280 BYTES DATA SRAM
- FLASH MEMORY SECURITY
- 2kB BOOT ROM
- PROGRAMMABLE WAIT STATE CONTROL

### Peripheral Features

- 34 I/O PINS
- ADDITIONAL 32-BIT ACCUMULATOR
- THREE 16-BIT TIMER/COUNTERS
- SYSTEM TIMERS
- PROGRAMMABLE WATCHDOG TIMER
- FULL DUPLEX DUAL UART
- MASTER/SLAVE SPI™ WITH DMA
- 16-BIT PWM
- POWER MANAGEMENT CONTROL
- IDLE MODE CURRENT < 1mA
- STOP MODE CURRENT < 1µA
- PROGRAMMABLE BROWNOUT RESET
- PROGRAMMABLE LOW VOLTAGE DETECT
- 21 INTERRUPT SOURCES
- TWO HARDWARE BREAKPOINTS

### GENERAL FEATURES

- PACKAGE: TQFP-64
- LOW POWER: 4mW
- INDUSTRIAL TEMPERATURE RANGE:  
-40°C to +85°C
- POWER SUPPLY: 2.7V to 5.25V

## APPLICATIONS

- INDUSTRIAL PROCESS CONTROL
- INSTRUMENTATION
- LIQUID/GAS CHROMATOGRAPHY
- BLOOD ANALYSIS
- SMART TRANSMITTERS
- PORTABLE INSTRUMENTS
- WEIGH SCALES
- PRESSURE TRANSDUCERS
- INTELLIGENT SENSORS
- PORTABLE APPLICATIONS
- DAS SYSTEMS

SPI is a registered trademark of Motorola.



Please be aware that an important notice concerning availability, standard warranty, and use in critical applications of Texas Instruments semiconductor products and disclaimers thereto appears at the end of this data sheet.

**PACKAGE/ORDERING INFORMATION**

SUNSTAR传感与控制 <http://www.sensor-ic.com/> TEL:0755-83376549 FAX:0755-83376182 E-MAIL:szss20@163.com

PRODUCT	FLASH MEMORY	PACKAGE-LEAD	PACKAGE DESIGNATOR <sup>(1)</sup>	SPECIFIED TEMPERATURE RANGE	PACKAGE MARKING	ORDERING NUMBER	TRANSPORT MEDIA, QUANTITY
MSC1210Y2	4k	TQFP-64	PAG	-40°C to +85°C	MSC1210Y2	MSC1210Y2PAGT	Tape and Reel, 250
MSC1210Y2	4k	"	"	"	"	MSC1210Y2PAGR	Tape and Reel, 2000
MSC1210Y3	8k	TQFP-64	PAG	-40°C to +85°C	MSC1210Y3	MSC1210Y3PAGT	Tape and Reel, 250
MSC1210Y3	8k	"	"	"	"	MSC1210Y3PAGR	Tape and Reel, 2000
MSC1210Y4	16k	TQFP-64	PAG	-40°C to +85°C	MSC1210Y4	MSC1210Y4PAGT	Tape and Reel, 250
MSC1210Y4	16k	"	"	"	"	MSC1210Y4PAGR	Tape and Reel, 2000
MSC1210Y5	32k	TQFP-64	PAG	-40°C to +85°C	MSC1210Y5	MSC1210Y5PAGT	Tape and Reel, 250
MSC1210Y5	32k	"	"	"	"	MSC1210Y5PAGR	Tape and Reel, 2000

NOTE: (1) For the most current specifications and package information, refer to our web site at [www.ti.com](http://www.ti.com).

**ABSOLUTE MAXIMUM RATINGS<sup>(1)</sup>**

Analog Inputs	
Input Current .....	100mA, Momentary
Input Current .....	10mA, Continuous
Input Voltage .....	AGND - 0.5V to AV <sub>DD</sub> + 0.5V
Power Supply	
DV <sub>DD</sub> to DGND .....	-0.3V to 6V
AV <sub>DD</sub> to AGND .....	-0.3V to 6V
AGND to DGND .....	-0.3V to +0.3V
V <sub>REF</sub> to AGND .....	-0.3V to AV <sub>DD</sub> + 0.3V
Digital Input Voltage to DGND .....	-0.3V to DV <sub>DD</sub> + 0.3V
Digital Output Voltage to DGND .....	-0.3V to DV <sub>DD</sub> + 0.3V
Maximum Junction Temperature .....	+150°C
Operating Temperature Range .....	-40°C to +85°C
Storage Temperature Range .....	-65°C to +150°C
Lead Temperature (soldering, 10s) .....	+300°C
Package Power Dissipation .....	900mW
Output Current All Pins .....	200mA
Output Pin Short Circuit .....	10s
Thermal Resistance, Junction-to-Ambient ( $\theta_{JA}$ ) .....	66.6°C/W
Thermal Resistance, Junction-to-Case ( $\theta_{JC}$ ) .....	4.3°C/W
Digital Outputs	
Output Current .....	100mA, Continuous
I/O Source/Sink Current .....	100mA
Power Pin Maximum .....	300mA

NOTE: (1) Stresses beyond those listed under "Absolute Maximum Ratings" may cause permanent damage to the device. Exposure to absolute-maximum-rated conditions for extended periods may affect device reliability.



**ELECTROSTATIC DISCHARGE SENSITIVITY**

This integrated circuit can be damaged by ESD. Texas Instruments recommends that all integrated circuits be handled with appropriate precautions. Failure to observe proper handling and installation procedures can cause damage.

ESD damage can range from subtle performance degradation to complete device failure. Precision integrated circuits may be more susceptible to damage because very small parametric changes could cause the device not to meet its published specifications.

**MSC1210YX FAMILY FEATURES**

FEATURES <sup>(1)</sup>	MSC1210Y2 <sup>(2)</sup>	MSC1210Y3 <sup>(2)</sup>	MSC1210Y4 <sup>(2)</sup>	MSC1210Y5 <sup>(2)</sup>
Flash Program Memory (Bytes)	Up to 4k	Up to 8k	Up to 16k	Up to 32k
Flash Data Memory (Bytes)	Up to 4k	Up to 8k	Up to 16k	Up to 32k
Internal Scratchpad RAM (Bytes)	256	256	256	256
Internal MOVX SRAM (Bytes)	1024	1024	1024	1024
Externally Accessible Memory (Bytes)	64k Program, 64k Data	64k Program, 64k Data	64k Program, 64k Data	64k Program, 64k Data

NOTES: (1) All peripheral features are the same on all devices; the flash memory size is the only difference. (2) The last digit of the part number (N) represents the onboard flash size = (2<sup>N</sup>)kBytes.

# ELECTRICAL CHARACTERISTICS: AV<sub>DD</sub> = 5V

SUNSTAR 传感器与执行器 <http://www.sensor-ic.com/> TEL: 0755-83376182 FAX: 0755-83376182 E-MAIL: szss20@163.com

All specifications from T<sub>MIN</sub> to T<sub>MAX</sub>, DV<sub>DD</sub> = +2.7V to 5.25V, f<sub>MOD</sub> = 15.625kHz, PGA = 1, Buffer ON, f<sub>DATA</sub> = 10Hz, Bipolar, V<sub>REF</sub> ≡ (REF IN+) – (REF IN-) = +2.5V, unless otherwise specified.

PARAMETER	CONDITION	MSC1210Yx			UNITS
		MIN	TYP	MAX	
<b>ANALOG INPUT</b> (AIN0-AIN7, AINCOM) Analog Input Range	Buffer OFF Buffer ON	AGND – 0.1 AGND		AV <sub>DD</sub> + 0.1 AV <sub>DD</sub> – 1.5 ±V <sub>REF</sub> /PGA	V V V
Full-Scale Input Voltage Range	(In+) – (In-) See Figure 4				V
Differential Input Impedance	Buffer OFF		5/PGA		MΩ
Input Current	Buffer ON		0.5		nA
Bandwidth					
Fast Settling Filter	–3dB		0.469 • f <sub>DATA</sub>		
Sinc <sup>2</sup> Filter	–3dB		0.318 • f <sub>DATA</sub>		
Sinc <sup>3</sup> Filter	–3dB		0.262 • f <sub>DATA</sub>		
Programmable Gain Amplifier	User-Selectable Gain Ranges	1		128	
Input Capacitance			9		pF
Input Leakage Current	Modulator Off. T = +25°C		0.5		pA
Burnout Current Sources	Input Open Circuit		±6		μA
<b>OFFSET DAC</b>					
Offset DAC Range		8	±V <sub>REF</sub> /(2 • PGA)		V
Offset DAC Monotonicity					Bits
Offset DAC Gain Error			±1.5		% of Range
Offset DAC Gain Error Drift			1		ppm/°C
<b>SYSTEM PERFORMANCE</b>					
Resolution		24			Bits
ENOB			22		Bits
Output Noise		See Typical Characteristics			
No Missing Codes	Sinc <sup>3</sup> Filter	24			Bits
Integral Nonlinearity	End Point Fit			±0.0015	%FSR
Offset Error	After Calibration		7.5		ppm of FS
Offset Drift <sup>(1)</sup>	Before Calibration		0.02		ppm of FS/°C
Gain Error	After Calibration		0.002		%
Gain Error Drift <sup>(1)</sup>	Before Calibration		0.5		ppm/°C
System Gain Calibration Range		80		120	% of FS
System Offset Calibration Range		–50		50	% of FS
Common-Mode Rejection	At DC	100	115		dB
	f <sub>CM</sub> = 60Hz, f <sub>DATA</sub> = 10Hz		130		dB
	f <sub>CM</sub> = 50Hz, f <sub>DATA</sub> = 50Hz		120		dB
	f <sub>CM</sub> = 60Hz, f <sub>DATA</sub> = 60Hz		120		dB
Normal Mode Rejection	f <sub>SIG</sub> = 50Hz, f <sub>DATA</sub> = 50Hz		100		dB
	f <sub>SIG</sub> = 60Hz, f <sub>DATA</sub> = 60Hz		100		dB
Power-Supply Rejection	At DC, dB = –20log(ΔV <sub>OUT</sub> /ΔV <sub>DD</sub> ) <sup>(2)</sup>	80	88		dB
<b>VOLTAGE REFERENCE INPUT</b>					
Reference Input Range	REF IN+, REF IN–	0.0		AV <sub>DD</sub>	V
V <sub>REF</sub>	V <sub>REF</sub> ≡ (REF IN+) – (REF IN–)	0.1	2.5	2.6	V
Common-Mode Rejection	At DC		130		dB
Common-Mode Rejection	f <sub>VREFCM</sub> = 60Hz, f <sub>DATA</sub> = 60Hz		120		dB
Input Current <sup>(3)</sup>	V <sub>REF</sub> = 2.5V		10		μA
<b>ON-CHIP VOLTAGE REFERENCE</b>					
Output Voltage	VREFH = 1 at +25°C VREFH = 0	2.495	2.5 1.25	2.505	V V
Power-Supply Rejection Ratio			65		dB
Short-Circuit Current Source			8		mA
Short-Circuit Current Sink			50		μA
Short-Circuit Duration	Sink or Source		Indefinite		
Drift			5		ppm/°C
Output Impedance	Sourcing 100uA		3		Ω
Startup Time from Power ON	C <sub>REF</sub> = 0.1μF		8		ms
Temperature Sensor					
Temperature Sensor Voltage	T = +25°C		115		mV
Temperature Sensor Coeff.			375		μV/°C
<b>ANALOG POWER-SUPPLY REQUIREMENTS</b>					
Power-Supply Voltage	AV <sub>DD</sub>	4.75		5.25	V
Analog Current (I <sub>ADC</sub> + I <sub>VREF</sub> )	Analog OFF, PDAD = 1		< 1		nA
ADC Current (I <sub>ADC</sub> )	PGA = 1, Buffer OFF		200		μA
	PGA = 128, Buffer OFF		500		μA
	PGA = 1, Buffer ON		240		μA
	PGA = 128, Buffer ON		850		μA
V <sub>REF</sub> Current (I <sub>VREF</sub> )			250		μA

NOTES: (1) Calibration can minimize these errors. (2) ΔV<sub>OUT</sub> is change in digital result. (3) 12pF switched capacitor at f<sub>SAMP</sub> clock frequency (see Figure 5).

# ELECTRICAL CHARACTERISTICS: AV<sub>DD</sub> = 3V

SUNSTAR 传感与控制 <http://www.sensor-ic.com> TEL: 0755-83376489 FAX: 0755-83376182 E-MAIL: szss20@163.com

All specifications from T<sub>MIN</sub> to T<sub>MAX</sub>, AV<sub>DD</sub> = +3V, DV<sub>DD</sub> = +2.7V to 5.25V, f<sub>MOD</sub> = 15.625kHz, PGA = 1, Buffer ON, f<sub>DATA</sub> = 10Hz, Bipolar, V<sub>REF</sub> ≡ (REF IN+) – (REF IN-) = +1.25V, unless otherwise specified.

PARAMETER	CONDITION	MSC1210Yx			UNITS
		MIN	TYP	MAX	
<b>ANALOG INPUT</b> (AIN0-AIN7, AINCOM) Analog Input Range	Buffer OFF Buffer ON	AGND – 0.1 AGND		AV <sub>DD</sub> + 0.1 AV <sub>DD</sub> – 1.5 ±V <sub>REF</sub> /PGA	V V V
Full-Scale Input Voltage Range	(In+) – (In-) See Figure 4				V
Differential Input Impedance	Buffer OFF		5/PGA		MΩ
Input Current	Buffer ON		0.5		nA
Bandwidth					
Fast Settling Filter	–3dB		0.469 • f <sub>DATA</sub>		
Sinc <sup>2</sup> Filter	–3dB		0.318 • f <sub>DATA</sub>		
Sinc <sup>3</sup> Filter	–3dB		0.262 • f <sub>DATA</sub>		
Programmable Gain Amplifier	User-Selectable Gain Ranges	1		128	
Input Capacitance			9		pF
Input Leakage Current	Modulator Off, T = +25°C		0.5		pA
Burnout Current Sources	Sensor Input Open Circuit		±6		μA
<b>OFFSET DAC</b>					
Offset DAC Range		8	±V <sub>REF</sub> /(2 • PGA)		V
Offset DAC Monotonicity					Bits
Offset DAC Gain Error			±1.5		% of Range
Offset DAC Gain Error Drift			1		ppm/°C
<b>SYSTEM PERFORMANCE</b>					
Resolution		24			Bits
ENOB			22		Bits
Output Noise			See Typical Characteristics		
No Missing Codes	Sinc <sup>3</sup> Filter	24			Bits
Integral Non-Linearity	End Point Fit, Differential Input			±0.0015	%FSR
Offset Error	After Calibration		7.5		ppm of FS
Offset Drift <sup>(1)</sup>	Before Calibration		0.02		ppm of FS/°C
Gain Error	After Calibration		0.010		%
Gain Error Drift <sup>(1)</sup>	Before Calibration		1.0		ppm/°C
System Gain Calibration Range		80		120	% of FS
System Offset Calibration Range		–50		50	% of FS
Common-Mode Rejection	At DC	100			dB
	f <sub>CM</sub> = 60Hz, f <sub>DATA</sub> = 10Hz		130		dB
	f <sub>CM</sub> = 50Hz, f <sub>DATA</sub> = 50Hz		120		dB
	f <sub>CM</sub> = 60Hz, f <sub>DATA</sub> = 60Hz		120		dB
Normal Mode Rejection	f <sub>SIG</sub> = 50Hz, f <sub>DATA</sub> = 50Hz		100		dB
	f <sub>SIG</sub> = 60Hz, f <sub>DATA</sub> = 60Hz		100		dB
Power-Supply Rejection	At DC, dB = –20log(DV <sub>OUT</sub> /DV <sub>DD</sub> ) <sup>(2)</sup>	75	85		dB
<b>VOLTAGE REFERENCE INPUT</b>					
Reference Input Range	REF IN+, REF IN–	0.0		AV <sub>DD</sub>	V
V <sub>REF</sub>	V <sub>REF</sub> ≡ (REF IN+) – (REF IN–)	0.1	1.25	1.3	V
Common-Mode Rejection	At DC		130		dB
Common-Mode Rejection	f <sub>VREFCM</sub> = 60Hz, f <sub>DATA</sub> = 60 Hz		120		dB
Input Current <sup>(3)</sup>	V <sub>REF</sub> = 1.25V		10		μA
<b>ON-CHIP VOLTAGE REFERENCE</b>					
Output Voltage	VREFH = 0 at +25°C	1.245	1.25	1.255	V
Power-Supply Rejection Ratio			65		dB
Short-Circuit Current Source			8		mA
Short-Circuit Current Sink			50		μA
Short-Circuit Duration	Sink or Source		Indefinite		
Drift			5		ppm/°C
Output Impedance	Sourcing 100uA		3		Ω
Startup Time from Power OFF	C <sub>REF</sub> = 0.1μF		5		ms
Temperature Sensor					
Temperature Sensor Voltage	T = +25°C		115		V
Temperature Sensor Coeff.			375		μV/°C
<b>POWER-SUPPLY REQUIREMENTS</b>					
Power-Supply Voltage	AV <sub>DD</sub>	2.7		3.6	V
Analog Current (I <sub>ADC</sub> + I <sub>VREF</sub> )	Analog OFF, PDAD = 1		1		nA
ADC Current (I <sub>ADC</sub> )	PGA = 1, Buffer OFF		200		μA
	PGA = 128, Buffer OFF		500		μA
	PGA = 1, Buffer ON		240		μA
	PGA = 128, Buffer ON		850		μA
V <sub>REF</sub> Current (I <sub>VREF</sub> )			240		μA

NOTES: (1) Calibration can minimize these errors. (2) DV<sub>OUT</sub> is change in digital result. (3) 12pF switched capacitor at f<sub>SAMP</sub> clock frequency (see Figure 5).

# DIGITAL CHARACTERISTICS: $DV_{DD} = 2.7V$ to $5.25V$

SUNSTAR/传感器控制 <http://www.sensor-ic.com/> TEL: 0755-83376182 FAX: 0755-83376182 E-MAIL: szss20@163.com

All specifications from  $T_{MIN}$  to  $T_{MAX}$ ,  $f_{OSC} = 1MHz$ , unless otherwise specified.

PARAMETER	CONDITION	MSC1210Yx			UNITS
		MIN	TYP	MAX	
POWER-SUPPLY REQUIREMENTS	$DV_{DD}$ Normal Mode, $f_{OSC} = 1MHz$ Normal Mode, $f_{OSC} = 8MHz$ Stop Mode	2.7	1.4 8 1	3.6 1.6 9	V mA mA $\mu A$
	$DV_{DD}$ Normal Mode, $f_{OSC} = 1MHz$ Normal Mode, $f_{OSC} = 8MHz$ Stop Mode	4.75	2 17 1	5.25 2.2 18	V mA mA $\mu A$
<b>DIGITAL INPUT/OUTPUT (CMOS)</b> Logic Level: $V_{IH}$ (except XIN pin) $V_{IL}$ (except XIN pin) Ports 0-3, Input Leakage Current, Input Mode Pins EA, XIN Input Leakage Current $V_{OL}$ , ALE, PSEN, Ports 0-3, All Output Modes $V_{OL}$ , ALE, PSEN, Ports 0-3, All Output Modes $V_{OH}$ , ALE, PSEN, Ports 0-3, Strong Drive Output $V_{OH}$ , ALE, PSEN, Ports 0-3, Strong Drive Output Ports 0-3 Pull-Up Resistors Pins ALE, PSEN, Pull-Up Resistors Pin RST, Pull Down Resistor	$V_{IH} = DV_{DD}$ or $V_{IH} = 0V$  $I_{OL} = 1mA$ $I_{OL} = 30mA$ $I_{OH} = 1mA$ $I_{OH} = 30mA$  Flash Programming Mode Only	$0.6 \cdot DV_{DD}$ DGND -10  DGND  $DV_{DD} - 0.4$	 0 0  1.5 $DV_{DD} - 0.1$ $DV_{DD} - 1.5$ 9 9 500	$DV_{DD}$ $0.2 \cdot DV_{DD}$ +10  0.4  $DV_{DD}$	V V $\mu A$ V V V V k $\Omega$ k $\Omega$ k $\Omega$

# FLASH MEMORY CHARACTERISTICS: $DV_{DD} = 2.7V$ to $5.25V$

PARAMETER	CONDITION	MSC1210Yx			UNITS
		MIN	TYP	MAX	
Flash Memory Endurance		100,000	1,000,000		cycles
Flash Memory Data Retention		100			Years

# AC ELECTRICAL CHARACTERISTICS(1)(2) - DV<sub>DD</sub> = 2.7V to 5.25V

SUNSTAR传感器与控制 <http://www.sensor-ic.com/> TEL: 0755-83376489 FAX: 0755-83376182 E-MAIL: szss20@163.com

SYMBOL	FIGURE	PARAMETER	2.7V to 3.6V		4.75V to 5.25V		UNITS
			MIN	MAX	MIN	MAX	
<b>System Clock</b> 1/t <sub>CLK</sub>	D	External Crystal Frequency (f <sub>OSC</sub> )	1	18	1	33	MHz
	D	External Clock Frequency (f <sub>OSC</sub> )	0	18	0	33	MHz
	D	External Ceramic Resonator Frequency (f <sub>OSC</sub> )	1	16	1	16	MHz
<b>Program Memory</b>	A	ALE Pulse Width	1.5t <sub>CLK</sub> - 5		1.5t <sub>CLK</sub> - 5		ns
	A	Address Valid to ALE LOW	0.5t <sub>CLK</sub> - 10		0.5t <sub>CLK</sub> - 7		ns
	A	Address Hold After ALE LOW	0.5t <sub>CLK</sub>		0.5t <sub>CLK</sub>		ns
	A	ALE LOW to Valid Instruction In		2.5t <sub>CLK</sub> - 35		2.5t <sub>CLK</sub> - 25	ns
	A	ALE LOW to $\overline{\text{PSEN}}$ LOW	0.5t <sub>CLK</sub>		0.5t <sub>CLK</sub>		ns
	A	$\overline{\text{PSEN}}$ Pulse Width	2t <sub>CLK</sub> - 5		2t <sub>CLK</sub> - 5		ns
	A	$\overline{\text{PSEN}}$ LOW to Valid Instruction In		2t <sub>CLK</sub> - 40		2t <sub>CLK</sub> - 30	ns
	A	Input Instruction Hold After $\overline{\text{PSEN}}$	5		-5		ns
	A	Input Instruction Float After $\overline{\text{PSEN}}$		t <sub>CLK</sub> - 5		t <sub>CLK</sub>	ns
	A	Address to Valid Instruction In		3t <sub>CLK</sub> - 40		3t <sub>CLK</sub> - 25	ns
A	$\overline{\text{PSEN}}$ LOW to Address Float		0		0	ns	
<b>Data Memory</b>	B	$\overline{\text{RD}}$ Pulse Width (t <sub>MCS</sub> = 0)	2t <sub>CLK</sub> - 5		2t <sub>CLK</sub> - 5		ns
	B	$\overline{\text{RD}}$ Pulse Width (t <sub>MCS</sub> > 0)	t <sub>MCS</sub> - 5		t <sub>MCS</sub> - 5		ns
	C	$\overline{\text{WR}}$ Pulse Width (t <sub>MCS</sub> = 0)	2t <sub>CLK</sub> - 5		2t <sub>CLK</sub> - 5		ns
	C	$\overline{\text{WR}}$ Pulse Width (t <sub>MCS</sub> > 0)	t <sub>MCS</sub> - 5		t <sub>MCS</sub> - 5		ns
	B	$\overline{\text{RD}}$ LOW to Valid Data In (t <sub>MCS</sub> = 0)		2t <sub>CLK</sub> - 40		2t <sub>CLK</sub> - 30	ns
	B	$\overline{\text{RD}}$ LOW to Valid Data In (t <sub>MCS</sub> > 0)		t <sub>MCS</sub> - 40		t <sub>MCS</sub> - 30	ns
	B	Data Hold After Read	-5		-5		ns
	B	Data Float After Read (t <sub>MCS</sub> = 0)		t <sub>CLK</sub>		t <sub>CLK</sub>	ns
	B	Data Float After Read (t <sub>MCS</sub> > 0)		2t <sub>CLK</sub>		2t <sub>CLK</sub>	ns
	B	ALE LOW to Valid Data In (t <sub>MCS</sub> = 0)		2.5t <sub>CLK</sub> - 40		2.5t <sub>CLK</sub> - 25	ns
	B	ALE LOW to Valid Data In (t <sub>MCS</sub> > 0)		t <sub>CLK</sub> + t <sub>MCS</sub> - 40		t <sub>CLK</sub> + t <sub>MCS</sub> - 25	ns
	B	Address to Valid Data In (t <sub>MCS</sub> = 0)		3t <sub>CLK</sub> - 40		3t <sub>CLK</sub> - 25	ns
	B	Address to Valid Data In (t <sub>MCS</sub> > 0)		1.5t <sub>CLK</sub> + t <sub>MCS</sub> - 40		1.5t <sub>CLK</sub> + t <sub>MCS</sub> - 25	ns
	B, C	ALE LOW to $\overline{\text{RD}}$ or $\overline{\text{WR}}$ LOW (t <sub>MCS</sub> = 0)	0.5t <sub>CLK</sub> - 5	0.5t <sub>CLK</sub> + 5	0.5t <sub>CLK</sub> - 5	0.5t <sub>CLK</sub> + 5	ns
	B, C	ALE LOW to $\overline{\text{RD}}$ or $\overline{\text{WR}}$ LOW (t <sub>MCS</sub> > 0)	t <sub>CLK</sub> - 5	t <sub>CLK</sub> + 5	t <sub>CLK</sub> - 5	t <sub>CLK</sub> + 5	ns
	B, C	Address to $\overline{\text{RD}}$ or $\overline{\text{WR}}$ LOW (t <sub>MCS</sub> = 0)	t <sub>CLK</sub> - 5		t <sub>CLK</sub> - 5		ns
	B, C	Address to $\overline{\text{RD}}$ or $\overline{\text{WR}}$ LOW (t <sub>MCS</sub> > 0)	2t <sub>CLK</sub> - 5		2t <sub>CLK</sub> - 5		ns
C	Data Valid to $\overline{\text{WR}}$ Transition	-8		-5		ns	
C	Data Hold After $\overline{\text{WR}}$	t <sub>CLK</sub> - 8		t <sub>CLK</sub> - 5		ns	
B	$\overline{\text{RD}}$ LOW to Address Float		-0.5t <sub>CLK</sub> - 5		-0.5t <sub>CLK</sub> - 5	ns	
B, C	$\overline{\text{RD}}$ or $\overline{\text{WR}}$ HIGH to ALE HIGH (t <sub>MCS</sub> = 0)	-5	5	-5	5	ns	
B, C	$\overline{\text{RD}}$ or $\overline{\text{WR}}$ HIGH to ALE HIGH (t <sub>MCS</sub> > 0)	t <sub>CLK</sub> - 5	t <sub>CLK</sub> + 5	t <sub>CLK</sub> - 5	t <sub>CLK</sub> + 5	ns	
<b>External Clock</b>	D	HIGH Time <sup>(3)</sup>	15		10		ns
	D	LOW Time <sup>(3)</sup>	15		10		ns
	D	Rise Time <sup>(3)</sup>		5		5	ns
	D	Fall Time <sup>(3)</sup>		5		5	ns

NOTES: (1) Parameters are valid over operating temperature range, unless otherwise specified. (2) Load capacitance for Port 0, ALE, and  $\overline{\text{PSEN}}$  = 100pF, load capacitance for all other outputs = 80pF. (3) These values are characterized but not 100% production tested. (4) t<sub>CLK</sub> = 1/f<sub>OSC</sub> = one oscillator clock period. (5) t<sub>MCS</sub> is a time period related to the Stretch MOVX selection. The following table shows the value of t<sub>MCS</sub> for each stretch selection.

MD2	MD1	MD0	MOVX DURATION	t <sub>MCS</sub>
0	0	0	2 Machine Cycles	0
0	0	1	3 Machine Cycles (default)	4t <sub>CLK</sub>
0	1	0	4 Machine Cycles	8t <sub>CLK</sub>
0	1	1	5 Machine Cycles	12t <sub>CLK</sub>
1	0	0	6 Machine Cycles	16t <sub>CLK</sub>
1	0	1	7 Machine Cycles	20t <sub>CLK</sub>
1	1	0	8 Machine Cycles	24t <sub>CLK</sub>
1	1	1	9 Machine Cycles	28t <sub>CLK</sub>

# EXPLANATION OF THE AC SYMBOLS

SUNSTAR自动化控制 <http://www.sensor-ic.com/> TEL: 0755-83376182 FAX: 0755-83376182 E-MAIL: szss20@163.com

Each Timing Symbol has five characters. The first character is always 't' (= time). The other characters, depending on their positions, indicate the name of a signal or the logical status of that signal. The designators are:

A—Address  
 C—Clock  
 D—Input Data  
 H—Logic Level HIGH  
 I—Instruction (program memory contents)  
 L—Logic Level LOW, or ALE  
 P— $\overline{\text{PSEN}}$   
 Q—Output Data

R— $\overline{\text{RD}}$  Signal  
 t—Time  
 V—Valid  
 W— $\overline{\text{WR}}$  Signal  
 X—No Longer a Valid Logic Level  
 Z—Float

Examples: (1)  $t_{\text{AVLL}}$  = Time for address valid to ALE LOW. (2)  $t_{\text{LLPL}}$  = Time for ALE LOW to  $\overline{\text{PSEN}}$  LOW.

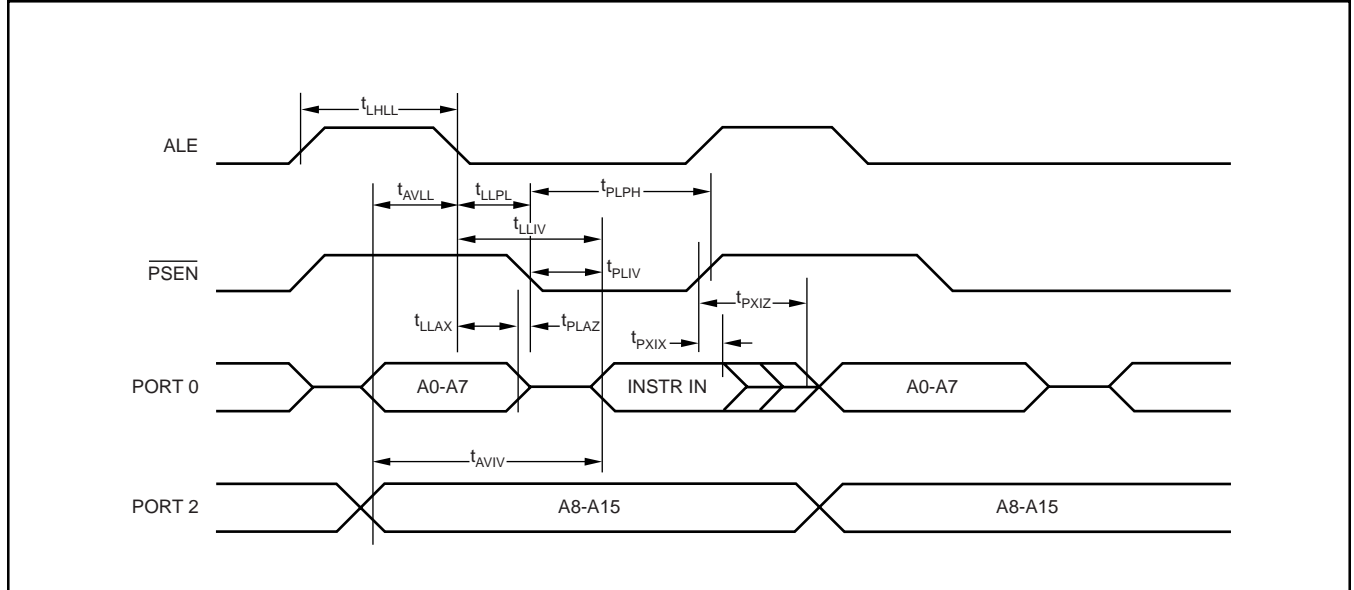

FIGURE A. External Program Memory Read Cycle

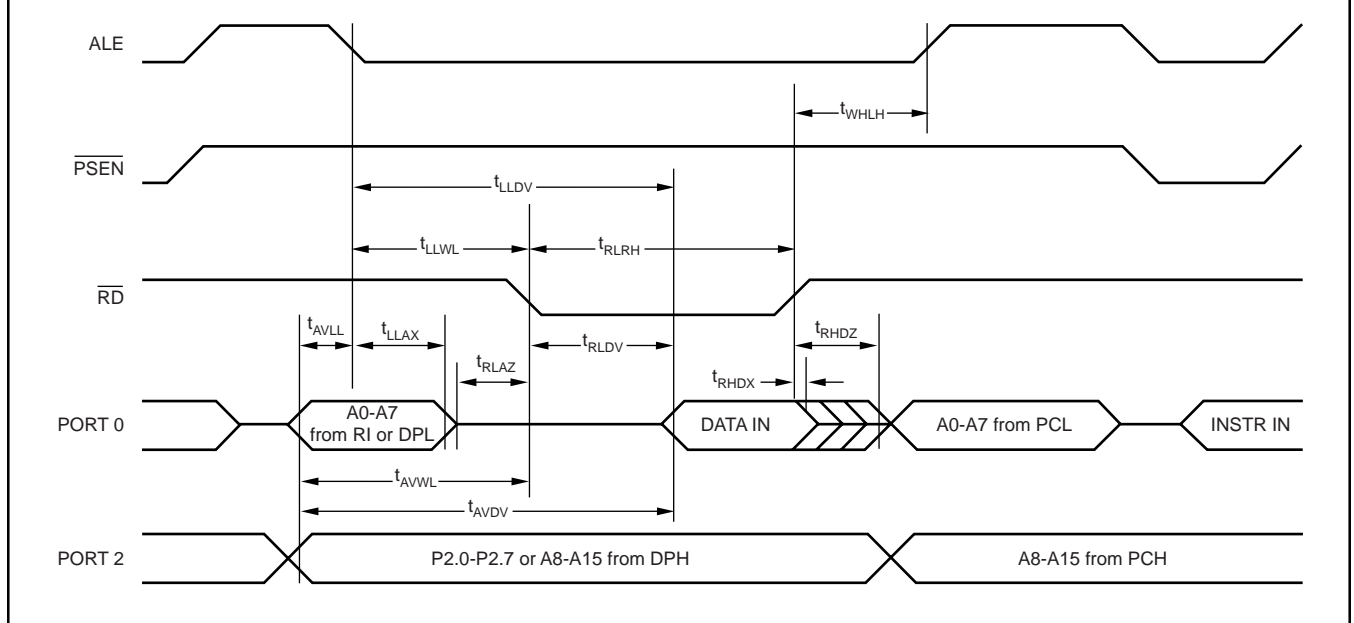

FIGURE B. External Data Memory Read Cycle

# EXPLANATION OF THE AC SYMBOLS (Cont.)

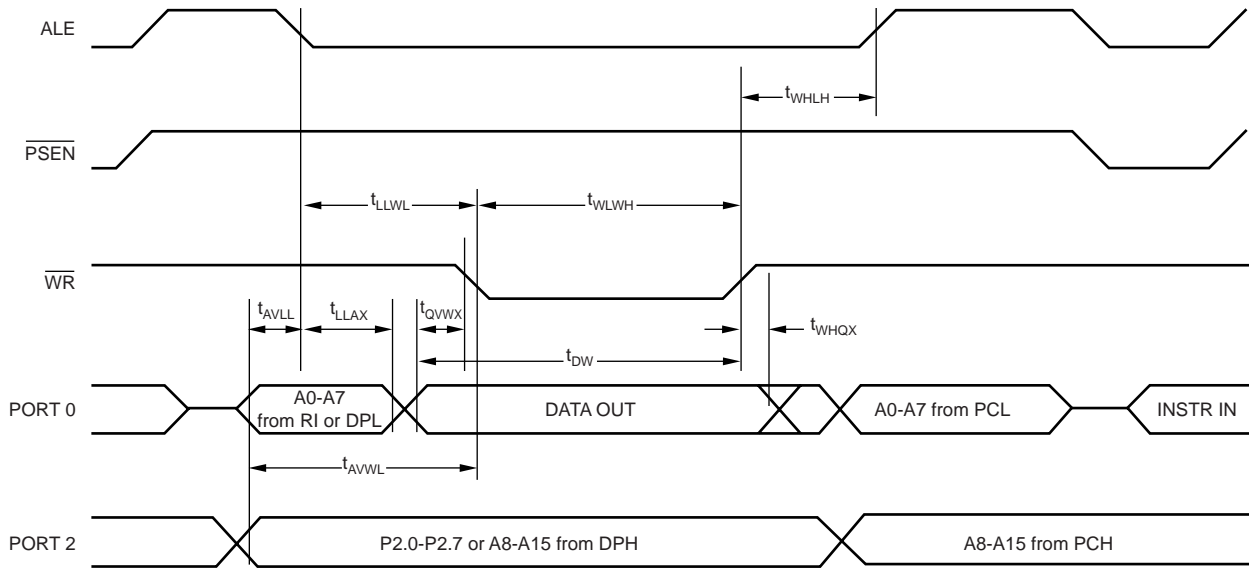

FIGURE C. External Data Memory Write Cycle

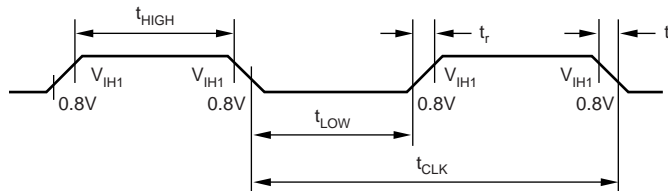
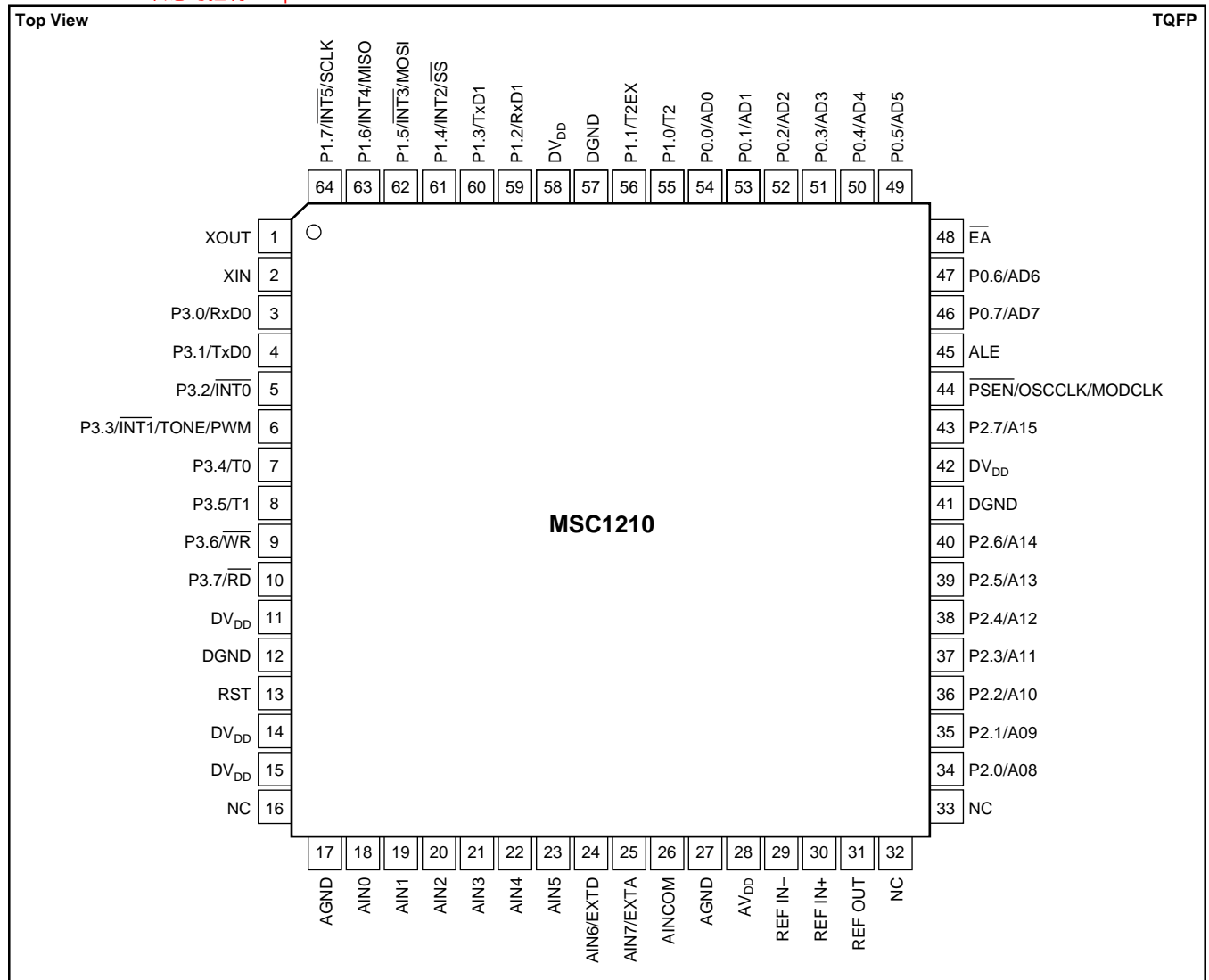

FIGURE D. External Clock Drive CLK

# PIN CONFIGURATION

SUNSTAR 传感与控制 <http://www.sensor-ic.com/> TEL:0755-83376549 FAX:0755-83376182 E-MAIL:szss20@163.com



## PIN DESCRIPTIONS

PIN #	NAME	DESCRIPTION																											
1	XOUT	The crystal oscillator pin XOUT supports parallel resonant AT cut crystals and ceramic resonators. XOUT serves as the output of the crystal amplifier.																											
2	XIN	The crystal oscillator pin XIN supports parallel resonant AT cut crystals and ceramic resonators. XIN can also be an input if there is an external clock source instead of a crystal.																											
3-10	P3.0-P3.7	Port 3 is a bidirectional I/O port. The alternate functions for Port3 are listed below. Port 3—Alternate Functions:																											
		<table border="1"> <thead> <tr> <th>PORT</th> <th>ALTERNATE</th> <th>MODE</th> </tr> </thead> <tbody> <tr> <td>P3.0</td> <td>RxD0</td> <td>Serial Port 0 Input</td> </tr> <tr> <td>P3.1</td> <td>TxD0</td> <td>Serial Port 0 Output</td> </tr> <tr> <td>P3.2</td> <td><math>\overline{\text{INT0}}</math></td> <td>External Interrupt 0</td> </tr> <tr> <td>P3.3</td> <td><math>\overline{\text{INT1}}</math>/TONE/PWM</td> <td>External Interrupt 1/TONE/PWM Output</td> </tr> <tr> <td>P3.4</td> <td>T0</td> <td>Timer 0 External Input</td> </tr> <tr> <td>P3.5</td> <td>T1</td> <td>Timer 1 External Input</td> </tr> <tr> <td>P3.6</td> <td><math>\overline{\text{WR}}</math></td> <td>External Data Memory Write Strobe</td> </tr> <tr> <td>P3.7</td> <td><math>\overline{\text{RD}}</math></td> <td>External Data Memory Read Strobe</td> </tr> </tbody> </table>	PORT	ALTERNATE	MODE	P3.0	RxD0	Serial Port 0 Input	P3.1	TxD0	Serial Port 0 Output	P3.2	$\overline{\text{INT0}}$	External Interrupt 0	P3.3	$\overline{\text{INT1}}$ /TONE/PWM	External Interrupt 1/TONE/PWM Output	P3.4	T0	Timer 0 External Input	P3.5	T1	Timer 1 External Input	P3.6	$\overline{\text{WR}}$	External Data Memory Write Strobe	P3.7	$\overline{\text{RD}}$	External Data Memory Read Strobe
PORT	ALTERNATE	MODE																											
P3.0	RxD0	Serial Port 0 Input																											
P3.1	TxD0	Serial Port 0 Output																											
P3.2	$\overline{\text{INT0}}$	External Interrupt 0																											
P3.3	$\overline{\text{INT1}}$ /TONE/PWM	External Interrupt 1/TONE/PWM Output																											
P3.4	T0	Timer 0 External Input																											
P3.5	T1	Timer 1 External Input																											
P3.6	$\overline{\text{WR}}$	External Data Memory Write Strobe																											
P3.7	$\overline{\text{RD}}$	External Data Memory Read Strobe																											
11, 14, 15, 42, 58	DV <sub>DD</sub>	Digital Power Supply																											
12, 41, 57	DGND	Digital Ground																											
13	RST	A HIGH on the reset input for two instruction clock cycles will reset the device.																											
16, 32, 33	NC	No Connection																											
17, 27	AGND	Analog Ground																											
28	AV <sub>DD</sub>	Analog Power Supply																											
18	AIN0	Analog Input Channel 0																											

**PIN DESCRIPTIONS (Cont.)**

PIN #	NAME	DESCRIPTION																											
19	AIN1	Analog Input Channel 1																											
20	AIN2	Analog Input Channel 2																											
21	AIN3	Analog Input Channel 3																											
22	AIN4	Analog Input Channel 4																											
23	AIN5	Analog Input Channel 5																											
24	AIN6, EXT0	Analog Input Channel 6, Digital Low Voltage Detect Input																											
25	AIN7, EXT1	Analog Input Channel 7, Analog Low Voltage Detect Input																											
26	AINCOM	Analog Common for Single-Ended Inputs																											
29	REF IN-	Voltage Reference Negative Input																											
30	REF IN+	Voltage Reference Positive Input																											
31	REF OUT	Voltage Reference Output																											
34-40, 43	P2.0-P2.7	Port 2 is a bidirectional I/O port. The alternate functions for Port 2 are listed below. Port 2—Alternate Functions:																											
<table border="1"> <thead> <tr> <th>PORT</th> <th>ALTERNATE</th> <th>MODE</th> </tr> </thead> <tbody> <tr><td>P2.0</td><td>A8</td><td>Address Bit 8</td></tr> <tr><td>P2.1</td><td>A9</td><td>Address Bit 9</td></tr> <tr><td>P2.2</td><td>A10</td><td>Address Bit 10</td></tr> <tr><td>P2.3</td><td>A11</td><td>Address Bit 11</td></tr> <tr><td>P2.4</td><td>A12</td><td>Address Bit 12</td></tr> <tr><td>P2.5</td><td>A13</td><td>Address Bit 13</td></tr> <tr><td>P2.6</td><td>A14</td><td>Address Bit 14</td></tr> <tr><td>P2.7</td><td>A15</td><td>Address Bit 15</td></tr> </tbody> </table>			PORT	ALTERNATE	MODE	P2.0	A8	Address Bit 8	P2.1	A9	Address Bit 9	P2.2	A10	Address Bit 10	P2.3	A11	Address Bit 11	P2.4	A12	Address Bit 12	P2.5	A13	Address Bit 13	P2.6	A14	Address Bit 14	P2.7	A15	Address Bit 15
PORT	ALTERNATE	MODE																											
P2.0	A8	Address Bit 8																											
P2.1	A9	Address Bit 9																											
P2.2	A10	Address Bit 10																											
P2.3	A11	Address Bit 11																											
P2.4	A12	Address Bit 12																											
P2.5	A13	Address Bit 13																											
P2.6	A14	Address Bit 14																											
P2.7	A15	Address Bit 15																											
44	$\overline{PSEN}$ OSCCLK MODCLK	Program Store Enable: Connected to optional external memory as a chip enable. $\overline{PSEN}$ will provide an active low pulse. In programming mode, $\overline{PSEN}$ is used as an input along with ALE to define serial or parallel programming mode. $\overline{PSEN}$ is held HIGH for parallel programming and tied LOW for serial programming. This pin can also be selected (when not using external program memory) to output the Oscillator clock, Modulator clock, HIGH, or LOW.																											
<table border="1"> <thead> <tr> <th>ALE</th> <th><math>\overline{PSEN}</math></th> <th>PROGRAM MODE SELECTION</th> </tr> </thead> <tbody> <tr><td>NC</td><td>NC</td><td>Normal Operation</td></tr> <tr><td>0</td><td>1</td><td>Parallel Programming</td></tr> <tr><td>1</td><td>0</td><td>Serial Programming</td></tr> <tr><td>0</td><td>0</td><td>Reserved</td></tr> </tbody> </table>			ALE	$\overline{PSEN}$	PROGRAM MODE SELECTION	NC	NC	Normal Operation	0	1	Parallel Programming	1	0	Serial Programming	0	0	Reserved												
ALE	$\overline{PSEN}$	PROGRAM MODE SELECTION																											
NC	NC	Normal Operation																											
0	1	Parallel Programming																											
1	0	Serial Programming																											
0	0	Reserved																											
45	ALE	Address Latch Enable: Used for latching the low byte of the address during an access to external memory. ALE is emitted at a constant rate of 1/2 the oscillator frequency, and can be used for external timing or clocking. One ALE pulse is skipped during each access to external data memory. In programming mode, ALE is used as an input along with $\overline{PSEN}$ to define serial or parallel programming mode. ALE is held HIGH for serial programming and tied LOW for parallel programming.																											
48	$\overline{EA}$	External Access Enable: $\overline{EA}$ must be externally held LOW to enable the device to fetch code from external program memory locations starting with 0000 <sub>H</sub> .																											
46, 47, 49-54	P0.0-P0.7	Port 0 is a bidirectional I/O port. The alternate functions for Port 0 are listed below. Port 0—Alternate Functions:																											
<table border="1"> <thead> <tr> <th>PORT</th> <th>ALTERNATE</th> <th>MODE</th> </tr> </thead> <tbody> <tr><td>P0.0</td><td>AD0</td><td>Address/Data Bit 0</td></tr> <tr><td>P0.1</td><td>AD1</td><td>Address/Data Bit 1</td></tr> <tr><td>P0.2</td><td>AD2</td><td>Address/Data Bit 2</td></tr> <tr><td>P0.3</td><td>AD3</td><td>Address/Data Bit 3</td></tr> <tr><td>P0.4</td><td>AD4</td><td>Address/Data Bit 4</td></tr> <tr><td>P0.5</td><td>AD5</td><td>Address/Data Bit 5</td></tr> <tr><td>P0.6</td><td>AD6</td><td>Address/Data Bit 6</td></tr> <tr><td>P0.7</td><td>AD7</td><td>Address/Data Bit 7</td></tr> </tbody> </table>			PORT	ALTERNATE	MODE	P0.0	AD0	Address/Data Bit 0	P0.1	AD1	Address/Data Bit 1	P0.2	AD2	Address/Data Bit 2	P0.3	AD3	Address/Data Bit 3	P0.4	AD4	Address/Data Bit 4	P0.5	AD5	Address/Data Bit 5	P0.6	AD6	Address/Data Bit 6	P0.7	AD7	Address/Data Bit 7
PORT	ALTERNATE	MODE																											
P0.0	AD0	Address/Data Bit 0																											
P0.1	AD1	Address/Data Bit 1																											
P0.2	AD2	Address/Data Bit 2																											
P0.3	AD3	Address/Data Bit 3																											
P0.4	AD4	Address/Data Bit 4																											
P0.5	AD5	Address/Data Bit 5																											
P0.6	AD6	Address/Data Bit 6																											
P0.7	AD7	Address/Data Bit 7																											
55, 56, 59-64	P1.0-P1.7	Port 1 is a bidirectional I/O port. The alternate functions for Port 1 are listed below. Port 1—Alternate Functions:																											
<table border="1"> <thead> <tr> <th>PORT</th> <th>ALTERNATE</th> <th>MODE</th> </tr> </thead> <tbody> <tr><td>P1.0</td><td>T2</td><td>T2 Input</td></tr> <tr><td>P1.1</td><td>T2EX</td><td>T2 External Input</td></tr> <tr><td>P1.2</td><td>RxD1</td><td>Serial Port Input</td></tr> <tr><td>P1.3</td><td>TxD1</td><td>Serial Port Output</td></tr> <tr><td>P1.4</td><td><math>\overline{INT2/SS}</math></td><td>External Interrupt/Slave Select</td></tr> <tr><td>P1.5</td><td><math>\overline{INT3/MOSI}</math></td><td>External Interrupt/Master Out-Slave In</td></tr> <tr><td>P1.6</td><td><math>\overline{INT4/MISO}</math></td><td>External Interrupt/Master In-Slave Out</td></tr> <tr><td>P1.7</td><td><math>\overline{INT5/SCK}</math></td><td>External Interrupt/Serial Clock</td></tr> </tbody> </table>			PORT	ALTERNATE	MODE	P1.0	T2	T2 Input	P1.1	T2EX	T2 External Input	P1.2	RxD1	Serial Port Input	P1.3	TxD1	Serial Port Output	P1.4	$\overline{INT2/SS}$	External Interrupt/Slave Select	P1.5	$\overline{INT3/MOSI}$	External Interrupt/Master Out-Slave In	P1.6	$\overline{INT4/MISO}$	External Interrupt/Master In-Slave Out	P1.7	$\overline{INT5/SCK}$	External Interrupt/Serial Clock
PORT	ALTERNATE	MODE																											
P1.0	T2	T2 Input																											
P1.1	T2EX	T2 External Input																											
P1.2	RxD1	Serial Port Input																											
P1.3	TxD1	Serial Port Output																											
P1.4	$\overline{INT2/SS}$	External Interrupt/Slave Select																											
P1.5	$\overline{INT3/MOSI}$	External Interrupt/Master Out-Slave In																											
P1.6	$\overline{INT4/MISO}$	External Interrupt/Master In-Slave Out																											
P1.7	$\overline{INT5/SCK}$	External Interrupt/Serial Clock																											



# TYPICAL CHARACTERISTICS

SUNSTAR 传感器与控制 <http://www.sensor-ic.com/> TEL: 0755-83376549 FAX: 0755-83376182 E-MAIL: szsss20@163.com

$AV_{DD} = +5V$ ,  $DV_{DD} = +5V$ ,  $f_{OSC} = 8MHz$ ,  $PGA = 1$ ,  $f_{DATA} = 10Hz$ , Buffer On,  $V_{REF} = (REF IN+) - (REF IN-) = +2.5V$ , unless otherwise specified.

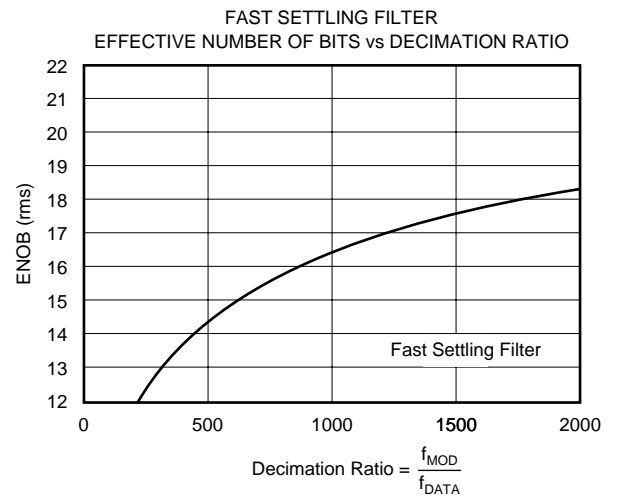
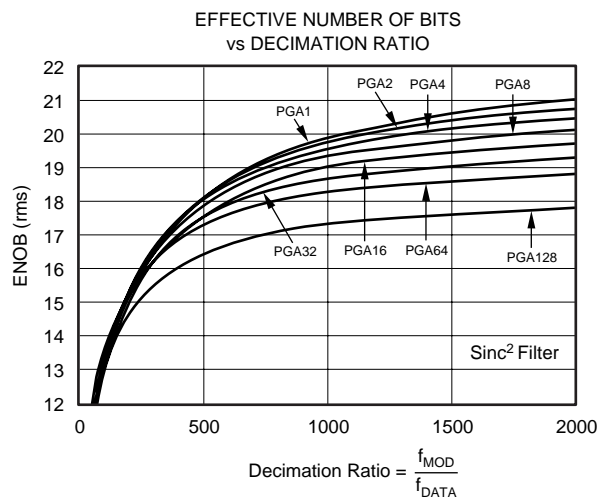
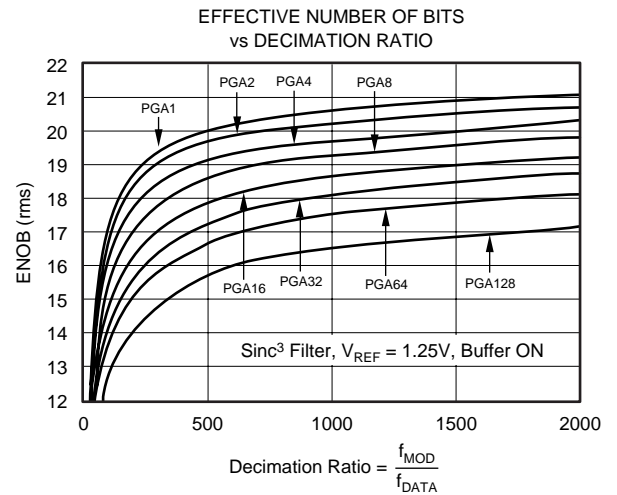
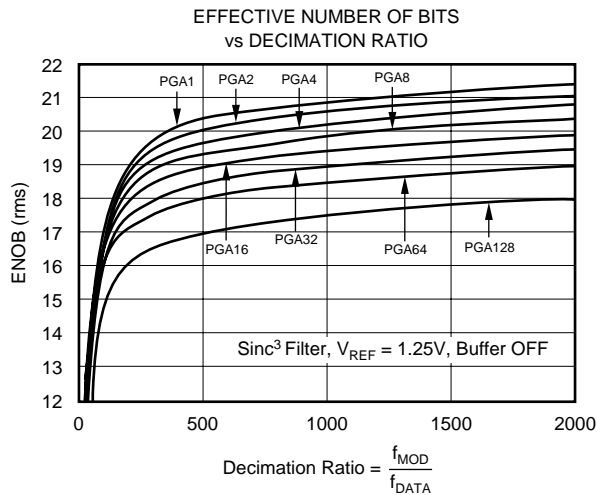
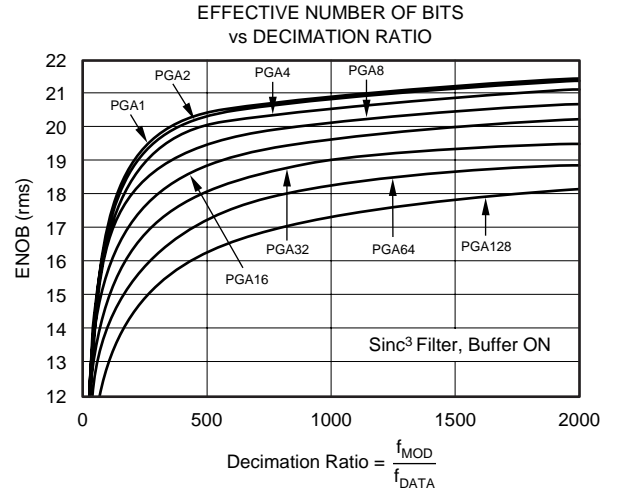
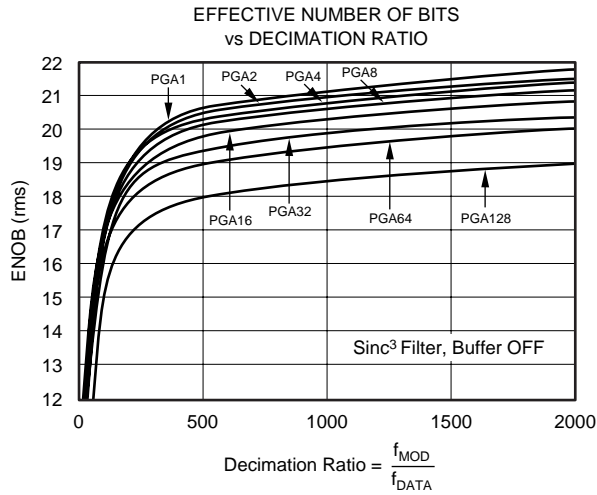

# TYPICAL CHARACTERISTICS (Cont.)

SUNSTAR自动化 <http://www.sensor-ic.com> TEL:0755-83376549 FAX:0755-83376182 E-MAIL:szsss20@163.com

$A_{V_{DD}} = +5V$ ,  $DV_{DD} = +5V$ ,  $f_{OSC} = 8MHz$ ,  $PGA = 1$ ,  $f_{DATA} = 10Hz$ , Buffer On,  $V_{REF} \equiv (REF\ IN+) - (REF\ IN-) = +2.5V$ , unless otherwise specified.

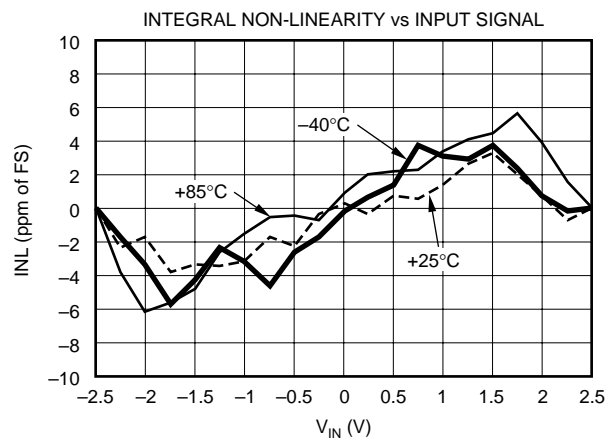
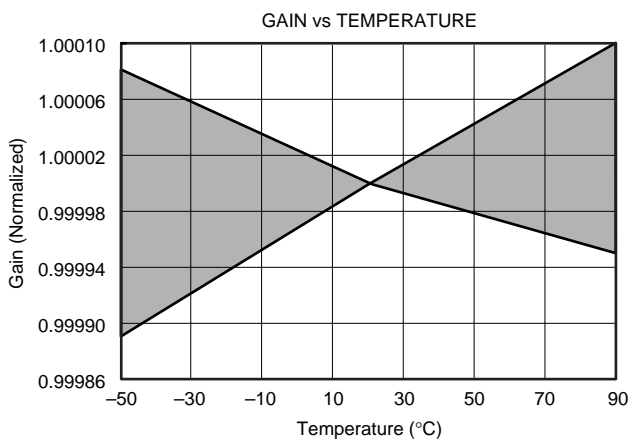
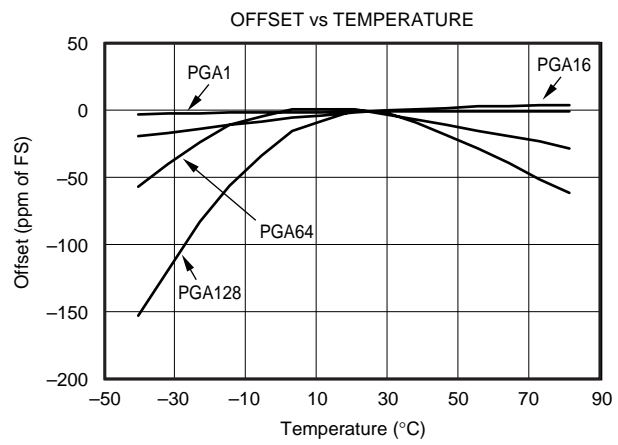
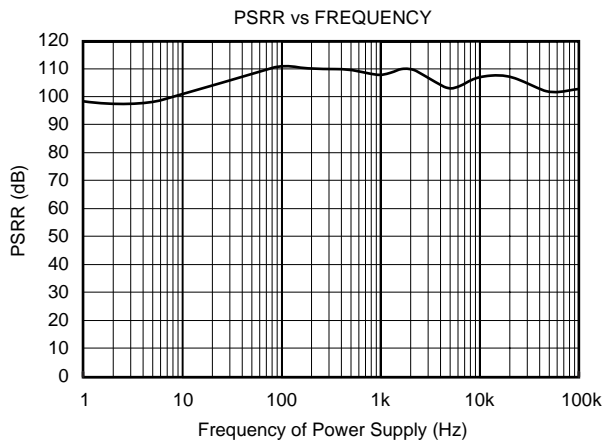
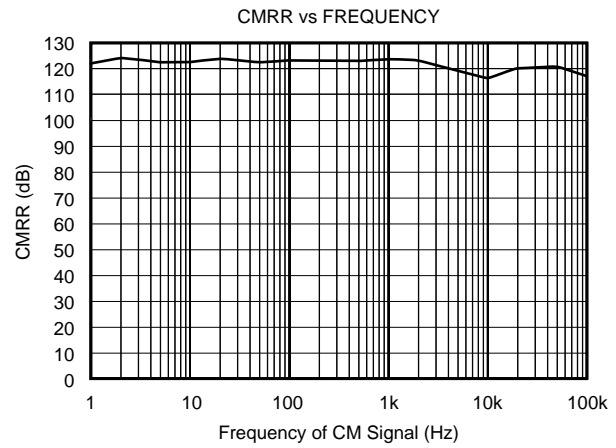
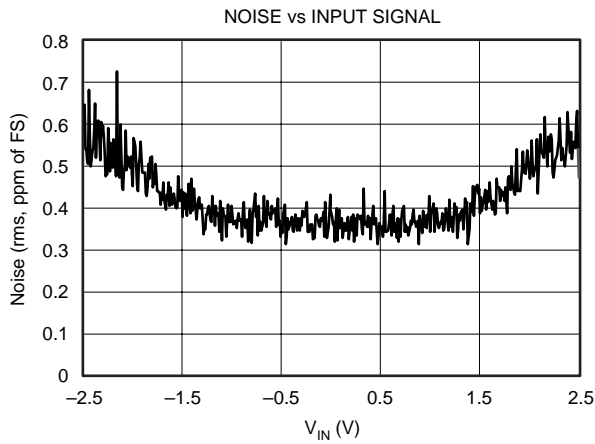

# TYPICAL CHARACTERISTICS (Cont.)

SUNSTAR 传感与控制 <http://www.sensor-ic.com/> TEL: 0755-83376182 FAX: 0755-83376182 E-MAIL: szss20@163.com

$V_{DD} = +5V$ ,  $DV_{DD} = +5V$ ,  $f_{OSC} = 8MHz$ ,  $PGA = 1$ ,  $f_{DATA} = 10Hz$ , Buffer On,  $0V_{REF} \equiv (REF IN+) - (REF IN-) = +2.5V$ , unless otherwise specified.

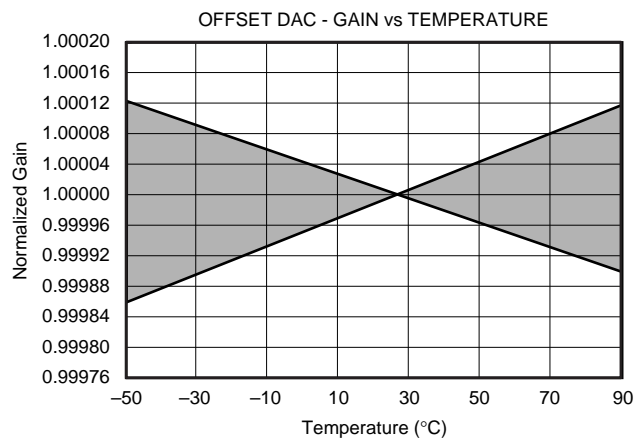
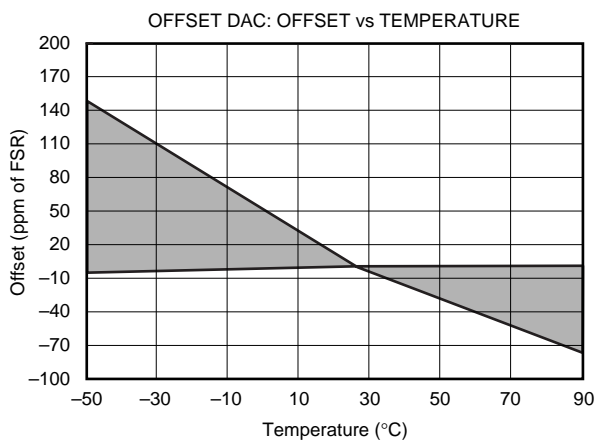
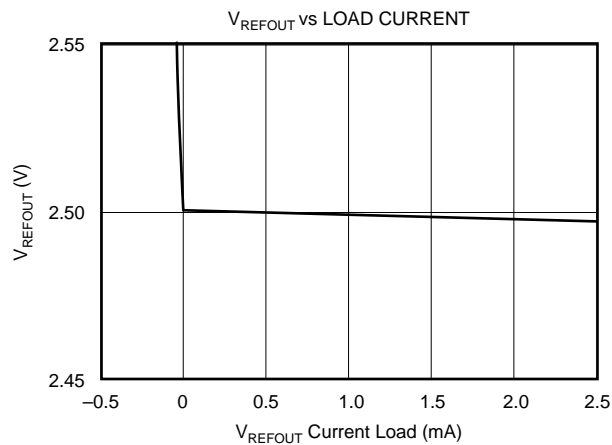
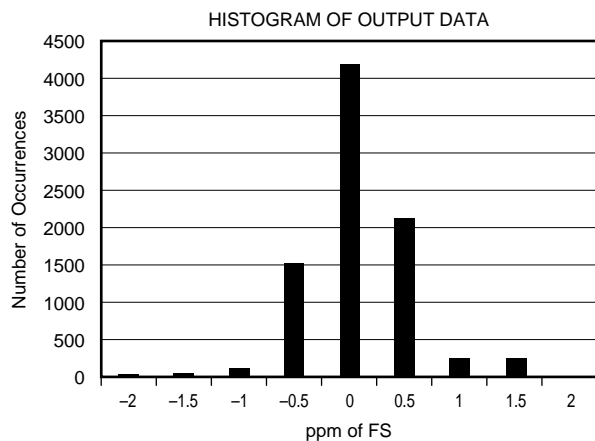
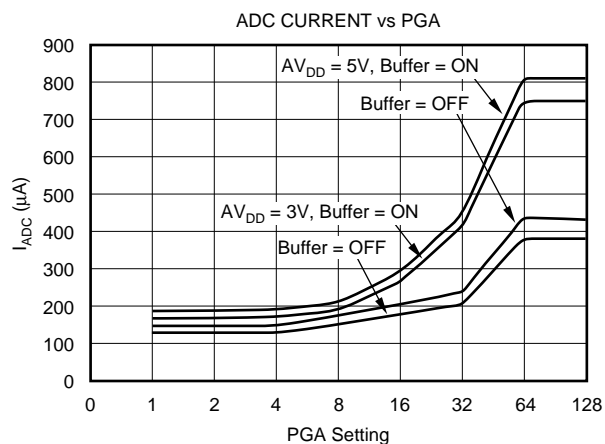
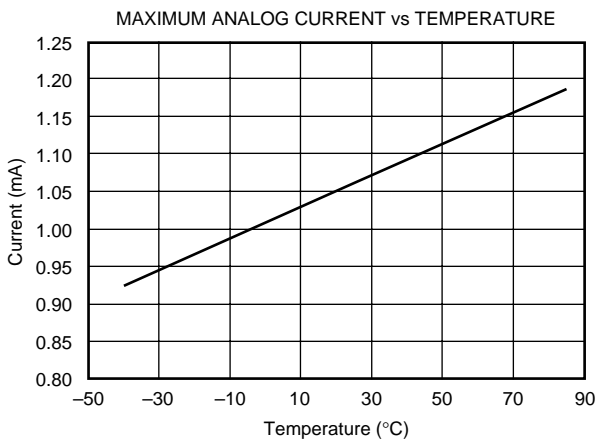

# TYPICAL CHARACTERISTICS (Cont.)

SUNSTAR自动化 <http://www.sensor-ic.com> TEL:0755-83376549 FAX:0755-83376182 E-MAIL:szsss20@163.com

$AV_{DD} = +5V$ ,  $DV_{DD} = +5V$ ,  $f_{OSC} = 8MHz$ ,  $PGA = 1$ ,  $f_{DATA} = 10Hz$ , Buffer On,  $V_{REF} \equiv (REF\ IN+) - (REF\ IN-) = +2.5V$ , unless otherwise specified.

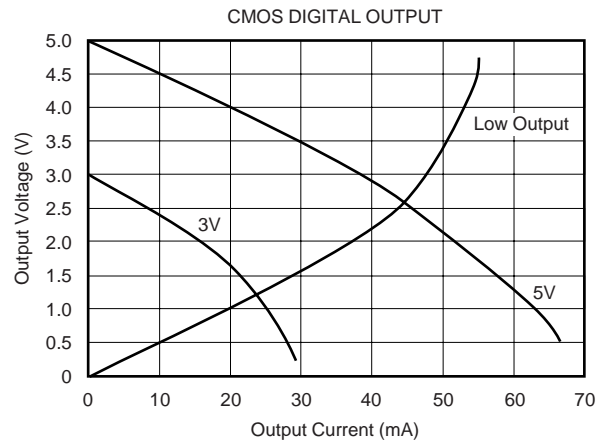
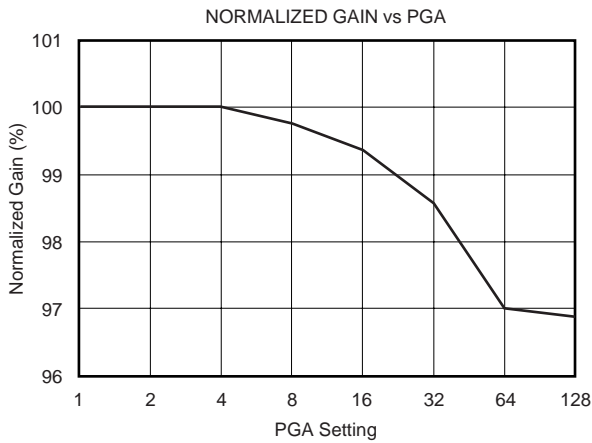
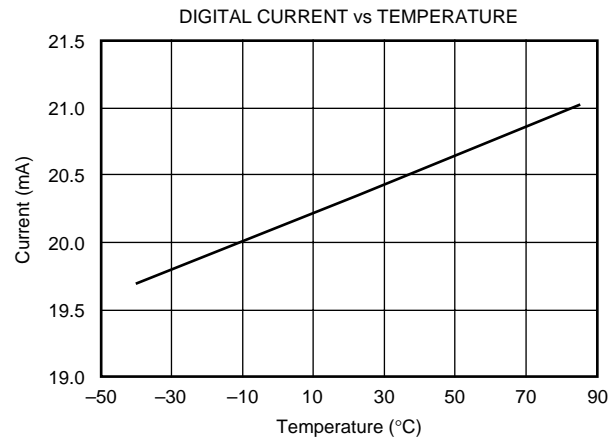
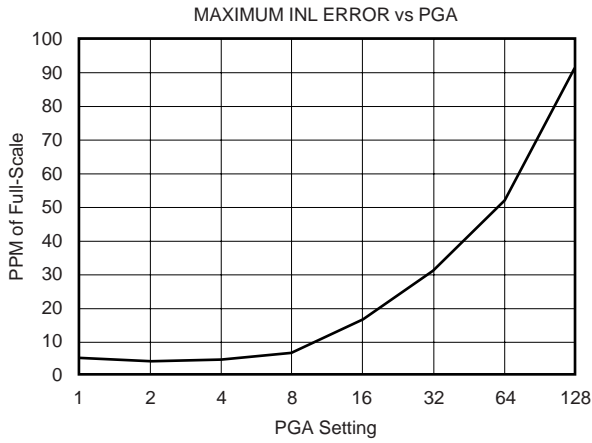
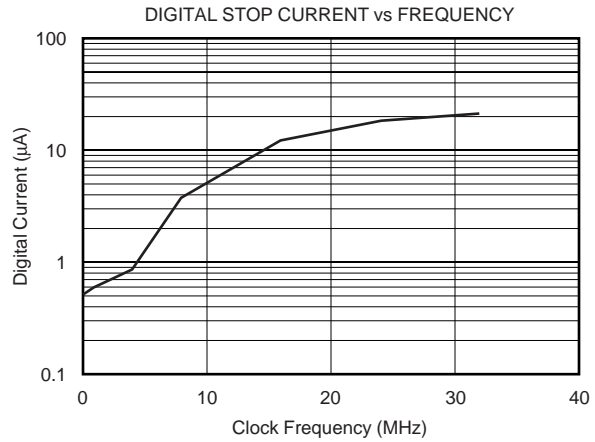
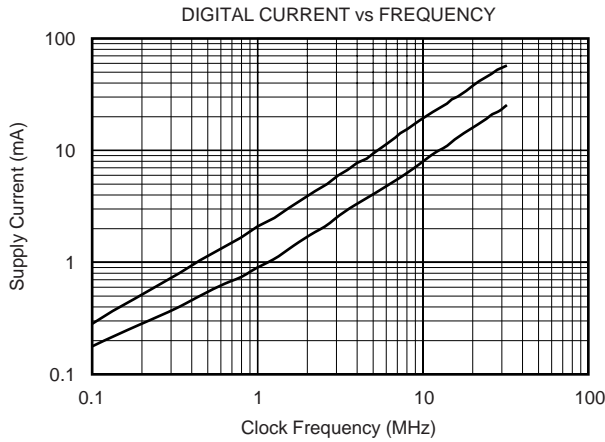

# DESCRIPTION

The MSC1210Yx is a completely integrated family of mixed-signal devices incorporating a high-resolution delta-sigma ADC, 8-channel multiplexer, burn-out current sources, selectable buffered input, offset DAC (Digital-to-Analog Converter), Programmable Gain Amplifier (PGA), temperature sensor, voltage reference, 8-bit microcontroller, Flash Program Memory, Flash Data Memory, Data SRAM, as shown in Figure 1.

On-chip peripherals include an additional 32-bit accumulator, an SPI compatible serial port with FIFO, dual UARTs, multiple digital input/output ports, watchdog timer, low-voltage detect, on-chip power-on reset, 16-bit PWM, breakpoints, brownout reset, and three timer/counters.

The device accepts low-level differential or single-ended signals directly from a transducer. The ADC provides 24 bits of resolution and 24 bits of no-missing-code performance using a sinc<sup>3</sup> filter with a programmable sample rate. The ADC also has a selectable filter that allows for high-resolution single-cycle conversion.

The microcontroller core is 8051 instruction set compatible. The microcontroller core is an optimized 8051 core which executes up to three times faster than the standard 8051 core, given the same clock source. That makes it possible to run the device at a lower external clock frequency and achieve the same performance at lower power than the standard 8051 core.

The MSC1210Yx allows the user to uniquely configure the Flash and SRAM memory maps to meet the needs of their application. The Flash is programmable down to 2.7V using both serial and parallel programming methods. The Flash endurance is 100k Erase/Write cycles. In addition, 1,280 bytes of RAM are incorporated on-chip.

The part has separate analog and digital supplies, which can be independently powered from 2.7V to +5.5V. At +3V operation, the power dissipation for the part is typically less than 4mW. The MSC1210Yx is packaged in a TQFP-64 package.

The MSC1210Yx is designed for high-resolution measurement applications in smart transmitters, industrial process control, weigh scales, chromatography, and portable instrumentation.

## ENHANCED 8051 CORE

All instructions in the MSC1210 family perform exactly the same functions as they would in a standard 8051. The effect on bits, flags, and registers is the same. However, the timing is different. The MSC1210 family utilizes an efficient 8051 core which results in an improved instruction execution speed of between 1.5 and 3 times faster than the original core for the same external clock speed (4 clock cycles per instruction versus 12 clock cycles per instruction, as shown in Figure 2). This translates into an effective throughput

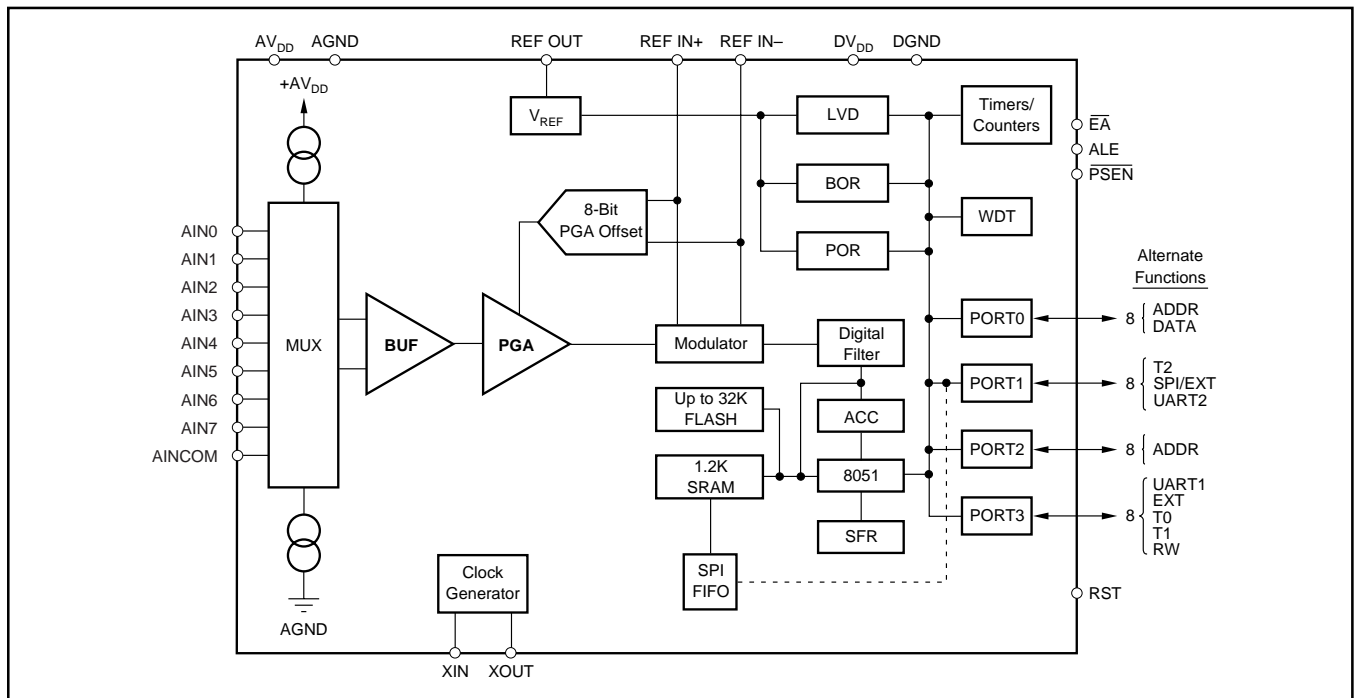

FIGURE 1. Block Diagram.

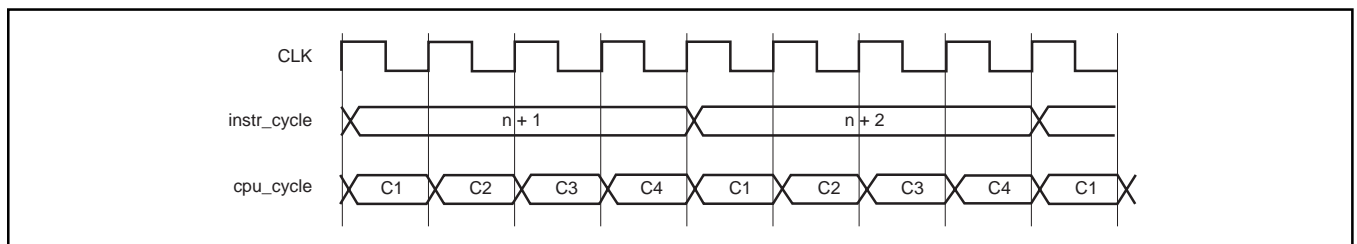

FIGURE 2. Instruction Cycle Timing.

improvement of more than 2.5 times, using the same code and same external clock speed. Therefore, a device frequency of 33MHz for the MSC1210Yx actually performs at an equivalent execution speed of 82.5MHz compared to the standard 8051 core. This allows the user to run the device at slower external clock speeds which reduces system noise and power consumption, but provides greater throughput. This performance difference can be seen in Figure 3. The timing of software loops will be faster with the MSC1210. However, the timer/counter operation of the MSC1210 may be maintained at 12 clocks per increment or optionally run at 4 clocks per increment.

The MSC1210 also provides dual data pointers (DPTRs) to speed block Data Memory moves.

Additionally, it can stretch the number of memory cycles to access external Data Memory from between two and nine instruction cycles in order to accommodate different speeds of memory or devices, as shown in Table I. The MSC1210 provides an external memory interface with a 16-bit address bus (P0 and P2). The 16-bit address bus makes it necessary

to multiplex the low address byte through the P0 port. To enhance P0 and P2 for high-speed memory access, hardware configuration control is provided to configure the ports for external memory/peripheral interface or general-purpose I/O.

Furthermore, improvements were made to peripheral features that offload processing from the core, and the user, to further improve efficiency. For instance, the SPI interface uses a FIFO, which allows the SPI interface to transmit and receive data with minimum overhead needed from the core. Also, a 32-bit accumulator was added to significantly reduce the processing overhead for the multiple byte data from the ADC or other sources. This allows for 24-bit addition and shifting to be accomplished in a few instruction cycles, compared to hundreds of instruction cycles through software implementation.

### Family Device Compatibility

The hardware functionality and pin configuration across the MSC1210 family is fully compatible. To the user the only difference between family members is the memory configuration. This makes migration between family members simple. Code written for the MSC1210Y2 can be executed directly on an MSC1210Y3, MSC1210Y4, or MSC1210Y5. This gives the user the ability to add or subtract software functions and to freely migrate between family members. Thus, the MSC1210 can become a standard device used across several application platforms.

### Family Development Tools

The MSC1210 is fully compatible with the standard 8051 instruction set. This means that the user can develop software for the MSC1210 with their existing 8051 development tools. Additionally, a complete, integrated development environment is provided with each demo board, and third party developers also provide support.

CKCON (8E <sub>H</sub> ) MD2:MD0	INSTRUCTION CYCLES (for MOVX)	$\overline{RD}$ or $\overline{WR}$ STROBE WIDTH (SYS CLKs)	$\overline{RD}$ or $\overline{WR}$ STROBE WIDTH ( $\mu$ s) AT 12MHz
000	2	2	0.167
001	3 (default)	4	0.333
010	4	8	0.667
011	5	12	1.000
100	6	16	1.333
101	7	20	1.667
110	8	24	2.000
111	9	28	2.333

TABLE I. Memory Cycle Stretching. Stretching of MOVX timing as defined by MD2, MD1, and MD0 bits in CKCON register (address 8E<sub>H</sub>).

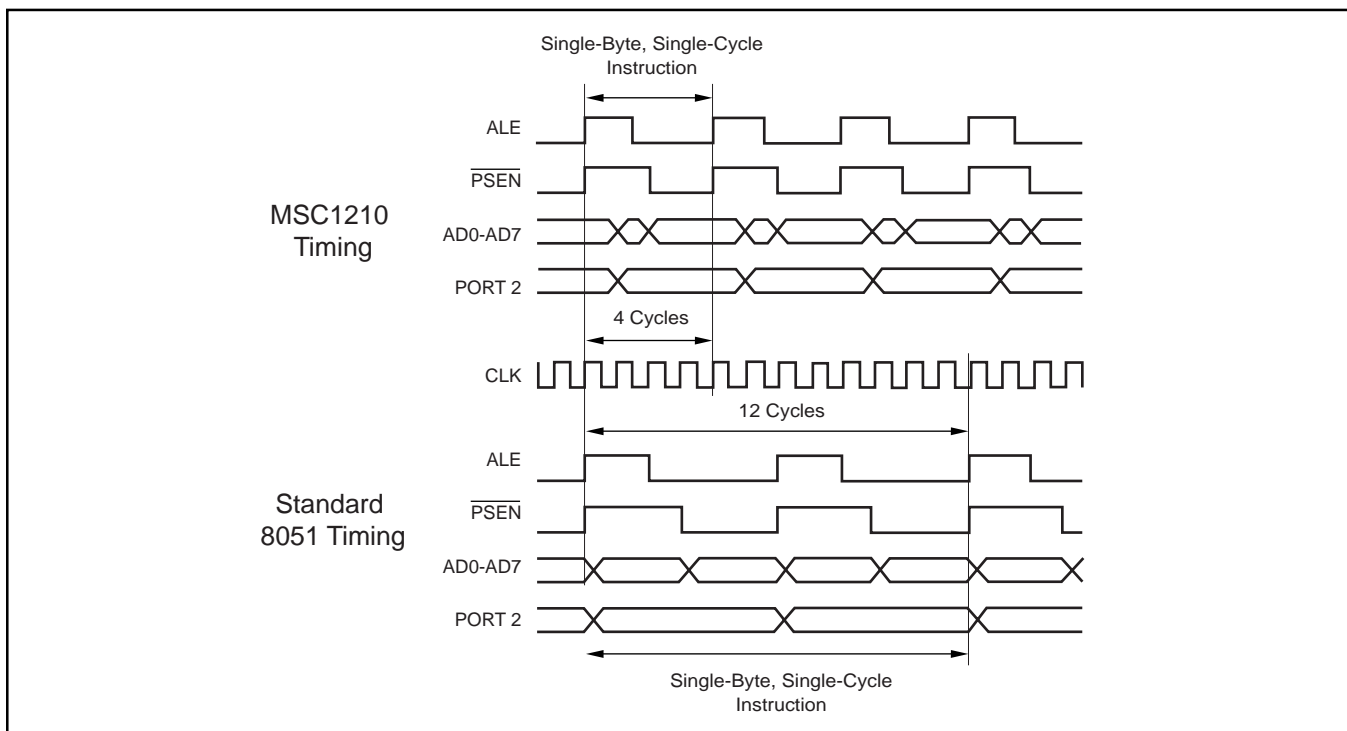

FIGURE 3. Comparison of MSC1210 Timing to Standard 8051 Timing.

# OVERVIEW

## INPUT MULTIPLEXER

The input multiplexer provides for any combination of differential inputs to be selected as the input channel, as shown in Figure 4. If A<sub>IN0</sub> is selected as the positive differential input channel, any other channel can be selected as the negative differential input channel. With this method, it is possible to have up to eight fully differential input channels. It is also possible to switch the polarity of the differential input pair to negate any offset voltages.

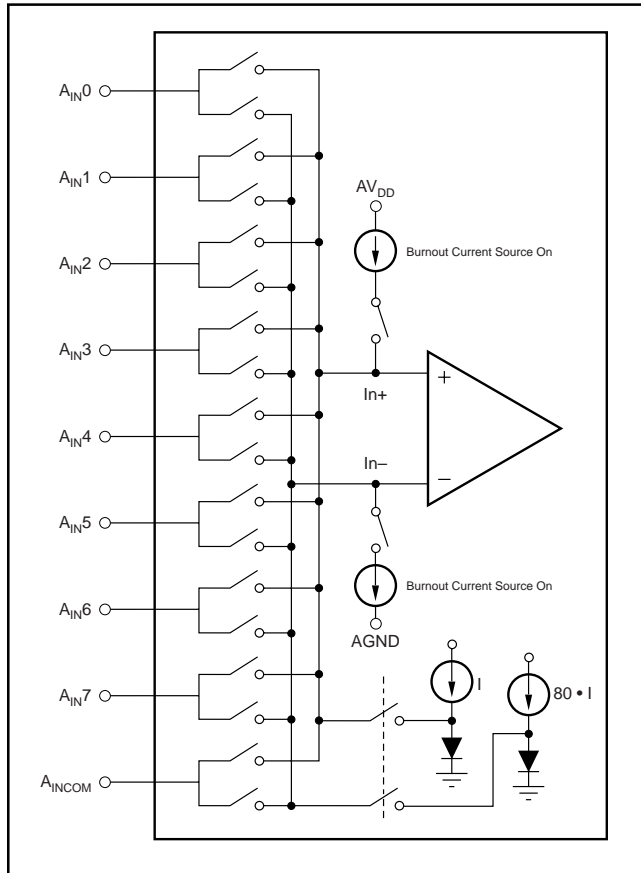

FIGURE 4. Input Multiplexer Configuration.

In addition, current sources are supplied that will source or sink current to detect open or short circuits on the pins.

## TEMPERATURE SENSOR

On-chip diodes provide temperature sensing capability. When the configuration register for the input MUX is set to all 1s, the diodes are connected to the input of the Analog-to-Digital Converter (ADC). All other channels are open.

## BURNOUT CURRENT SOURCES

When the Burnout Detect (BOD) bit is set in the ADC control configuration register (ADCON0 DC<sub>H</sub>), two current sources are enabled. The current source on the positive input channel sources approximately 2μA of current. The current source on the negative input channel sinks approximately 2μA. This allows for the detection of an open circuit (full-scale reading) or short circuit (small differential reading) on the selected input differential pair.

## INPUT BUFFER

The analog input impedance is always high, regardless of PGA setting (when the buffer is enabled). With the buffer enabled, the input voltage range is reduced and the analog power-supply current is higher. If the limitation of input voltage range is acceptable, then the buffer is always beneficial.

The input impedance of the MSC1210 without the buffer is 5MΩ/PGA. The buffer is controlled by the state of the BUF bit in the ADC control register (ADCON0 DC<sub>H</sub>).

## ANALOG INPUT

When the buffer is not selected, the input impedance of the analog input changes with clock frequency (ACLK F<sub>6H</sub>) and gain (PGA). The relationship is:

$$A_{IN} \text{ Impedance } (\Omega) = \left( \frac{1 \cdot 10^6}{ACLK \text{ Frequency}} \right) \cdot \left( \frac{5 \cdot 10^6}{PGA} \right)$$

Figure 5 shows the basic input structure of the MSC1210.

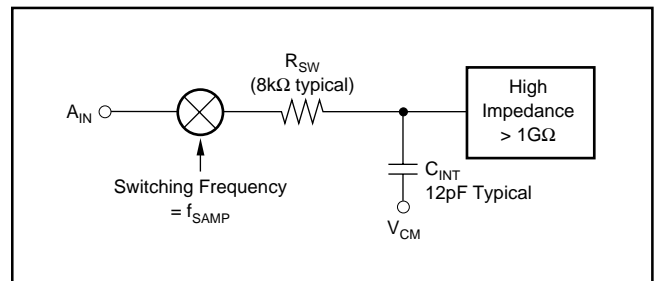

FIGURE 5. Analog Input Structure.

## PGA

The Programmable Gain Amplifier (PGA) can be set to gains of 1, 2, 4, 8, 16, 32, 64, or 128. Using the PGA can actually improve the effective resolution of the ADC. For instance, with a PGA of 1 on a 5V full-scale range, the ADC can resolve to 1μV. With a PGA of 128 on a 40mV full-scale range, the ADC can resolve to 75nV. With a PGA of 1 on a 5V full-scale range, it would require a 26-bit ADC to resolve 76nV.

## PGA OFFSET DAC

The analog input to the PGA can be offset by up to half the full-scale input range of the PGA by using the ODAC register (SFR E6<sub>H</sub>). The ODAC (Offset DAC) register is an 8-bit value; the MSB is the sign and the seven LSBs provide the magnitude of the offset. Since the ODAC introduces an analog (instead of digital) offset to the PGA, using the ODAC does not reduce the performance of the ADC.

## MODULATOR

The modulator is a single-loop second-order system. The modulator runs at a clock speed (f<sub>MOD</sub>) that is derived from the CLK using the value in the Analog Clock register (ACLK). The data output rate = (ACLK + 1)/64/(Decimation Ratio).

## CALIBRATION

SUNSTAR传感与控制 <http://www.sensor-ic.com/> TEL:0755-83376489 FAX:0755-83376182 E-MAIL:szss20@163.com

The offset and gain errors in the MSC1210, or the complete system, can be reduced with calibration. Calibration is controlled through the ADON1 register (SFR DD<sub>H</sub>), bits CAL2:CAL0. Each calibration process takes seven  $t_{DATA}$  periods (data conversion time) to complete. Therefore, it takes 14  $t_{DATA}$  periods to complete both an offset and gain calibration.

For system calibration, the appropriate signal must be applied to the inputs. The system offset command requires a “zero” differential input signal. It then computes an offset that will nullify offset in the system. The system gain command requires a positive “full-scale” differential input signal. It then computes a value to nullify gain errors in the system. Each of these calibrations will take seven  $t_{DATA}$  periods to complete.

Calibration should be performed after power on, a change in temperature, decimation ratio, buffer, or a change of the PGA. Calibration will remove the effects of the Offset DAC, therefore, changes to the Offset DAC register must be done after calibration.

At the completion of calibration, the ADC Interrupt bit goes HIGH which indicates the calibration is finished and valid data is available.

## DIGITAL FILTER

The Digital Filter can use either the Fast Settling, Sinc<sup>2</sup>, or Sinc<sup>3</sup> filter, as shown in Figure 6. In addition, the Auto mode changes the Sinc filter after the input channel or PGA is changed. When switching to a new channel, it will use the

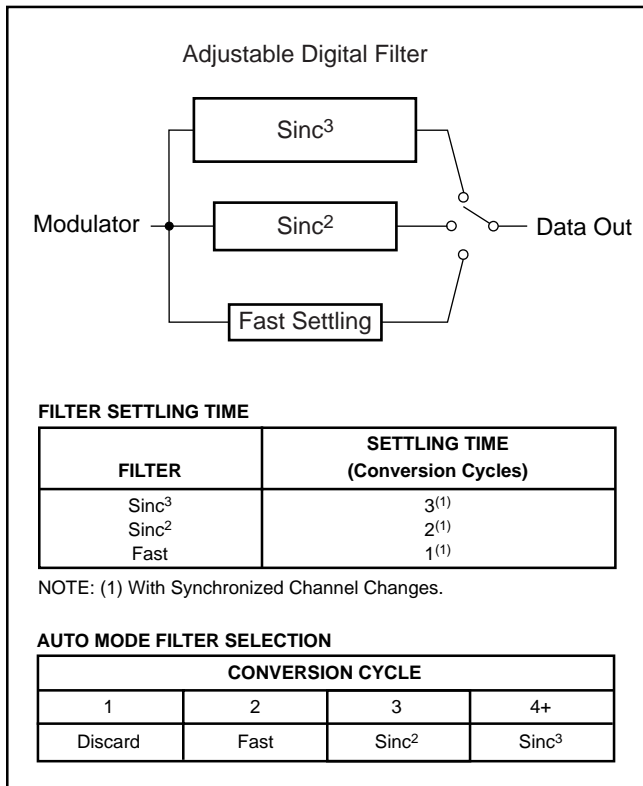

FIGURE 6. Filter Step Responses.

Fast Settling filter for the next two conversions the first of which should be discarded. It will then use the Sinc<sup>2</sup> followed by the Sinc<sup>3</sup> filter to improve noise performance. This combines the low-noise advantage of the Sinc<sup>3</sup> filter with the quick response of the Fast Settling Time filter. The frequency response of each filter is shown in Figure 7.

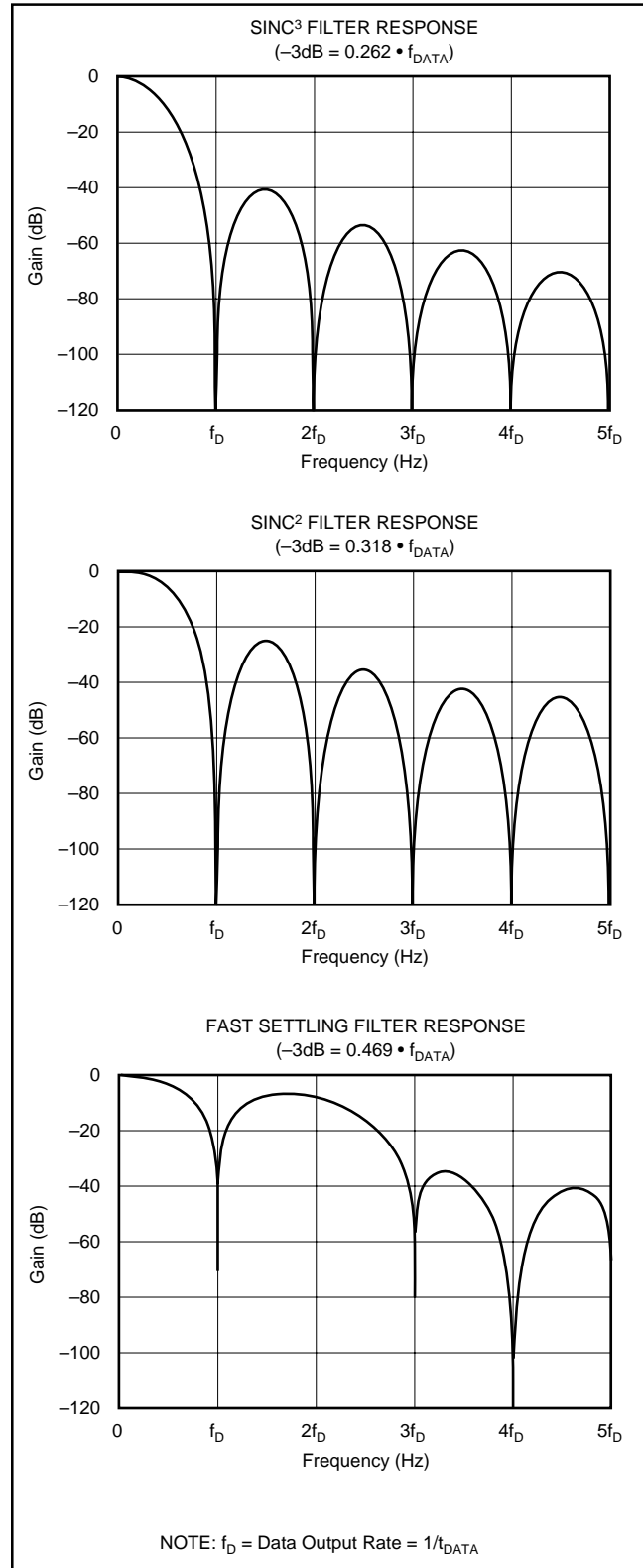

FIGURE 7. Filter Frequency Responses.

The voltage reference used for the MSC1210 can either be internal or external. The power-up configuration for the voltage reference is 2.5V internal. The selection for the voltage reference is made through the ADCON0 register (SFR DC<sub>H</sub>). The internal voltage reference is selectable as either 1.25V (AV<sub>DD</sub> = 2.7V to 5.25V) or 2.5V (AV<sub>DD</sub> = 4.5V to 5.25V). If the internal V<sub>REF</sub> is not used, it should be turned off to reduce noise and power consumption. The V<sub>REFOUT</sub> pin should have a 0.1μF capacitor to AGND.

The external voltage reference is differential and is represented by the voltage difference between the pins: REF IN+ and REF IN-. The absolute voltage on either pin (REF IN+ and REF IN-) can range from AGND to AV<sub>DD</sub>, however, the differential voltage must not exceed 2.6V. The differential voltage reference provides easy means of performing ratiometric measurement.

**POWER-UP—SUPPLY VOLTAGE RAMP RATE**

The built-in (on-chip) power-on reset circuitry was designed to accommodate analog or digital supply ramp rates as slow as 1V/10ms. To ensure proper operation, the power supply should ramp monotonically at the specified rate.

**MEMORY MAP**

The MSC1210 contains on-chip SFR, Flash Memory, Scratchpad Memory, Boot ROM, and SRAM. The SFR registers are primarily used for control and status. The standard 8051 features and additional peripheral features of the MSC1210 are controlled through the SFR. Reading from undefined SFR will return zero and writing to undefined SFR registers is not recommended and will have indeterminate effects.

Flash Memory is used for both Program Memory and Data Memory. The user has the ability to select the partition size of Program and Data Memories. The partition size is set through hardware configuration bits, which are programmed through either the parallel or serial programming methods. Both Program and Data Flash Memories are erasable and writable (programmable) in user application mode. However, only program execution can occur from Program Memory. As an added precaution, a lock feature can be activated through the hardware configuration bits, which disables erase and writes to 4kB of Program Flash Memory or the entire Program Flash Memory in user application mode.

The MSC1210 includes 1kB of SRAM on-chip. SRAM starts at address 0 and is accessed through the MOVX instruction. This SRAM can also be located to start at 8400<sub>H</sub> and can be accessed as both Program and Data Memory.

The MSC1210 uses a memory addressing scheme that separates Program Memory (FLASH/ROM) from Data Memory (FLASH/RAM). Each area is 64kB beginning at address 0000<sub>H</sub> and ending at FFFF<sub>H</sub>, as shown in Figure 8. The program and data segments can overlap since they are accessed in different ways. Program Memory is fetched by the microcontroller automatically. There is one instruction (MOVC) that is used to explicitly read the program area. This is commonly used to read lookup tables. The Data Memory area is accessed explicitly using the MOVX instruction. This instruction provides multiple ways of specifying the target address. It is used to access the 64kB of Data Memory. The address and data range of devices with on-chip Program and Data Memory overlap the 64kB memory space. When on-chip memory is enabled, accessing memory in the on-chip range will cause the device to access internal memory. Memory accesses beyond the internal range will be addressed externally via Ports 0 and 2.

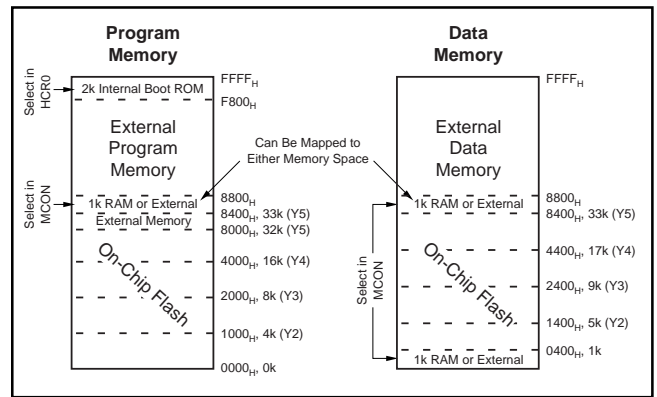

FIGURE 8. Memory Map.

The MSC1210 has two Hardware Configuration registers (HCR0 and HCR1) that are programmable only during Flash Memory Programming mode.

The MSC1210 allows the user to partition the Flash Memory between Program Memory and Data Memory. For instance, the MSC1210Y5 contains 32kB of Flash Memory on-chip. Through the HW configuration registers, the user can define the partition between Program Memory (PM) and Data Memory (DM), as shown in Table II. The MSC1210 family offers four memory configurations, as shown.

HCR0	MSC1210Y2		MSC1210Y3		MSC1210Y4		MSC1210Y5	
DFSEL	PM	DM	PM	DM	PM	DM	PM	DM
000	0kB	4kB	0kB	8kB	—	—	—	—
001	0kB	4kB	0kB	8kB	—	—	0kB	32kB
010	0kB	4kB	0kB	8kB	0kB	16kB	16kB	16kB
011	0kB	4kB	0kB	8kB	8kB	8kB	24kB	8kB
100	0kB	4kB	4kB	4kB	12kB	4kB	28kB	4kB
101	2kB	2kB	6kB	2kB	14kB	2kB	30kB	2kB
110	3kB	1kB	7kB	1kB	15kB	1kB	31kB	1kB
111 (default)	4kB	0kB	8kB	0kB	16kB	0kB	32kB	0kB

NOTE: When a 0kB program memory configuration is selected program execution is external. “—” is reserved.

TABLE II. MSC1210Y Flash Partitioning.

HCRO	MSC1210Y2		MSC1210Y3		MSC1210Y4		MSC1210Y5	
	PM	DM	PM	DM	PM	DM	PM	DM
000 (reserved)	—	—	—	—	—	—	—	—
001	0000	0400-13FF	0000	0400-23FF	0000	0400-43FF	0000	0400-83FF
010	0000	0400-13FF	0000	0400-23FF	0000	0400-43FF	0000-3FFF	0400-43FF
011	0000	0400-13FF	0000	0400-23FF	0000-1FFF	0400-23FF	0000-5FFF	0400-23FF
100	0000	0400-13FF	0000-0FFF	0400-13FF	0000-2FFF	0400-13FF	0000-6FFF	0400-13FF
101	0000-07FF	0400-0BFF	0000-17FF	0400-0BFF	0000-37FF	0400-0BFF	0000-77FF	0400-0BFF
110	0000-0BFF	0400-07FF	0000-1BFF	0400-07FF	0000-3BFF	0400-07FF	0000-7BFF	0400-07FF
111 (default)	0000-0FFF	0000	0000-1FFF	0000	0000-3FFF	0000	0000-7FFF	0000

NOTE: Program memory accesses above the highest listed address will access external program memory.

TABLE III. Flash Memory Partitioning.

It is important to note that the Flash Memory is readable and writable (depending on the MXWS bit in the MWS SFR) by the user through the MOVX instruction when configured as either Program or Data Memory. This means that the user may partition the device for maximum Flash Program Memory size (no Flash Data Memory) and use Flash Program Memory as Flash Data Memory. This may lead to undesirable behavior if the PC points to an area of Flash Program Memory that is being used for data storage. Therefore, it is recommended to use Flash partitioning when Flash Memory is used for data storage. Flash partitioning prohibits execution of code from Data Flash Memory. Additionally, the Program Memory erase/write can be disabled through hardware configuration bits (HCRO), while still providing access (read/write/erase) to Data Flash Memory.

The effect of memory mapping on Program and Data Memory is straightforward. The Program Memory is decreased in size from the top of internal Program Memory. Therefore, if the MSC1210Y5 is partitioned with 31kB of Flash Program Memory and 1kB of Flash Data Memory, external Program Memory execution will begin at 7C00<sub>H</sub> (versus 8000<sub>H</sub> for 32kB). The Flash Data Memory is added on top of the SRAM memory. Therefore, access to Data Memory (through MOVX) will access SRAM for addresses 0000<sub>H</sub>-03FF<sub>H</sub> and access Flash Memory for addresses 0400<sub>H</sub>-07FF<sub>H</sub>.

### Data Memory

The MSC1210 can address 64kB of Data Memory. Scratchpad Memory provides 256 bytes in addition to the 64kB of Data Memory. The MOVX instruction is used to access the Data SRAM Memory. This includes 1,024 bytes of on-chip Data SRAM Memory. The data bus values do not appear on Port 0 (during data bus timing) for internal memory access.

The MSC1210 also has on-chip Flash Data Memory which is readable and writable (depending on Memory Write Select register) during normal operation (full V<sub>DD</sub> range). This memory is mapped into the external Data Memory space directly above the SRAM.

### REGISTER MAP

TEL: 0755-83376489 FAX: 0755-83376182 E-MAIL: szss20@163.com

The Register Map is illustrated in Figure 9. It is entirely separate from the Program and Data Memory areas mentioned before. A separate class of instructions is used to access the registers. There are 256 potential register locations. In practice, the MSC1210 has 256 bytes of Scratchpad RAM and up to 128 SFRs. This is possible, since the upper 128 Scratchpad RAM locations can only be accessed indirectly. That is, the contents of a Working Register (described below) will designate the RAM location. Thus, a direct reference to one of the upper 128 locations must be an SFR access. Direct RAM is reached at locations 0 to 7F<sub>H</sub> (0 to 127).

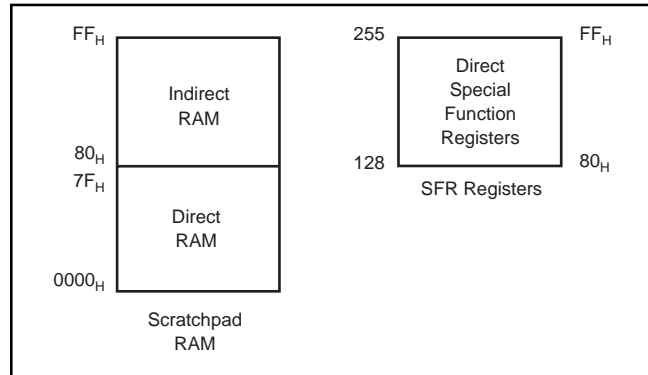

FIGURE 9. Register Map.

SFRs are accessed directly between 80<sub>H</sub> and FF<sub>H</sub> (128 to 255). The RAM locations between 128 and 255 can be reached through an indirect reference to those locations. Scratchpad RAM is available for general-purpose data storage. It is commonly used in place of off-chip RAM when the total data contents are small. When off-chip RAM is needed, the Scratchpad area will still provide the fastest general-purpose access. Within the 256 bytes of RAM, there are several special-purpose areas.

### Bit Addressable Locations

In addition to direct register access, some individual bits are also accessible. These are individually addressable bits in both the RAM and SFR area. In the Scratchpad RAM area, registers 20<sub>H</sub> to 2F<sub>H</sub> are bit addressable. This provides 128 (16 • 8) individual bits available to software. A bit access is distinguished from a full-register access by the type of instruction. In the SFR area, any register location ending in a 0 or 8 is bit addressable. Figure 9 shows details of the on-chip RAM addressing including the locations of individual RAM bits.

### Working Registers

As part of the lower 128 bytes of RAM, there are four banks of Working Registers (each). The Working Registers are general-purpose RAM locations that can be addressed in a special way. They are designated R0 through R7. Since there are four banks, the currently selected bank will be used by any instruction using R0-R7. This allows software to change context by simply switching banks. This is controlled via the Program Status Word register (PSW; 0D0<sub>H</sub>) in the SFR area described below. The Working Registers also allow their contents to be used for indirect address-

ing of the upper 128 bytes of RAM. Thus, an instruction can designate the value stored in R0 (for example) to address the upper RAM. The 16 bytes immediately above these registers are bit addressable. So any of the 128 bits in this area can be directly accessed using bit addressable instructions.

### Stack

Another use of the Scratchpad area is for the programmer's stack. This area is selected using the Stack Pointer (SP;81<sub>H</sub>) SFR. Whenever a call or interrupt is invoked, the return address is placed on the Stack. It also is available to the programmer for variables, etc., since the Stack can be moved and there is no fixed location within the RAM designated as Stack. The Stack Pointer will default to 07<sub>H</sub> on reset. The user can then move it as needed. A convenient location would be the upper RAM area (> 7F<sub>H</sub>) since this is only available indirectly. The SP will point to the last used value. Therefore, the next value placed on the Stack is put at SP + 1. Each PUSH or CALL will increment the SP by the appropriate value. Each POP or RET will decrement as well.

### Program Memory

After reset, the CPU begins execution from Program Memory location 0000<sub>H</sub>. The selection of where Program Memory execution begins is made by tying the  $\overline{E\bar{A}}$  pin to  $V_{DD}$  for internal access, or DGND for external access. When  $\overline{E\bar{A}}$  is tied to  $V_{DD}$ , any PC fetches outside the internal Program Memory address occur from external memory. If  $\overline{E\bar{A}}$  is tied to DGND, then all PC fetches address external memory. The standard internal Program Memory size for MSC1210 family members is shown in Table IV. Refer to the Accessing External Memory section for details on using external Program Memory. If enabled the Boot ROM will appear from address F800<sub>H</sub> to FFFF<sub>H</sub>.

MODEL NUMBER	STANDARD INTERNAL PROGRAM MEMORY SIZE (BYTES)
MSC1210Y5	32k
MSC1210Y4	16k
MSC1210Y3	8k
MSC1210Y2	4k

TABLE IV. MSC1210 Maximum Internal Program Memory Sizes.

### ACCESSING EXTERNAL MEMORY

If external memory is used, P0 and P2 can be configured as address and data lines. If external memory is not used, P0 and P2 can be configured as general-purpose I/O lines through the Hardware Configuration Register.

To enable access to external memory bits 0 and 1 of the HCR1 register must be set to 0. When these bits are enabled all memory accesses for both internal and external memory will appear on ports 0 and 2. During the data portion of the cycle for internal memory, Port 0 will be zero for security purposes.

Accesses to external memory are of two types: accesses to external Program Memory and accesses to external Data Memory. Accesses to external Program Memory use signal  $\overline{PSEN}$  (program store enable) as the read strobe. Accesses to external Data Memory use  $\overline{RD}$  or  $\overline{WR}$  (alternate functions of P3.7 and P3.6) to strobe the memory.

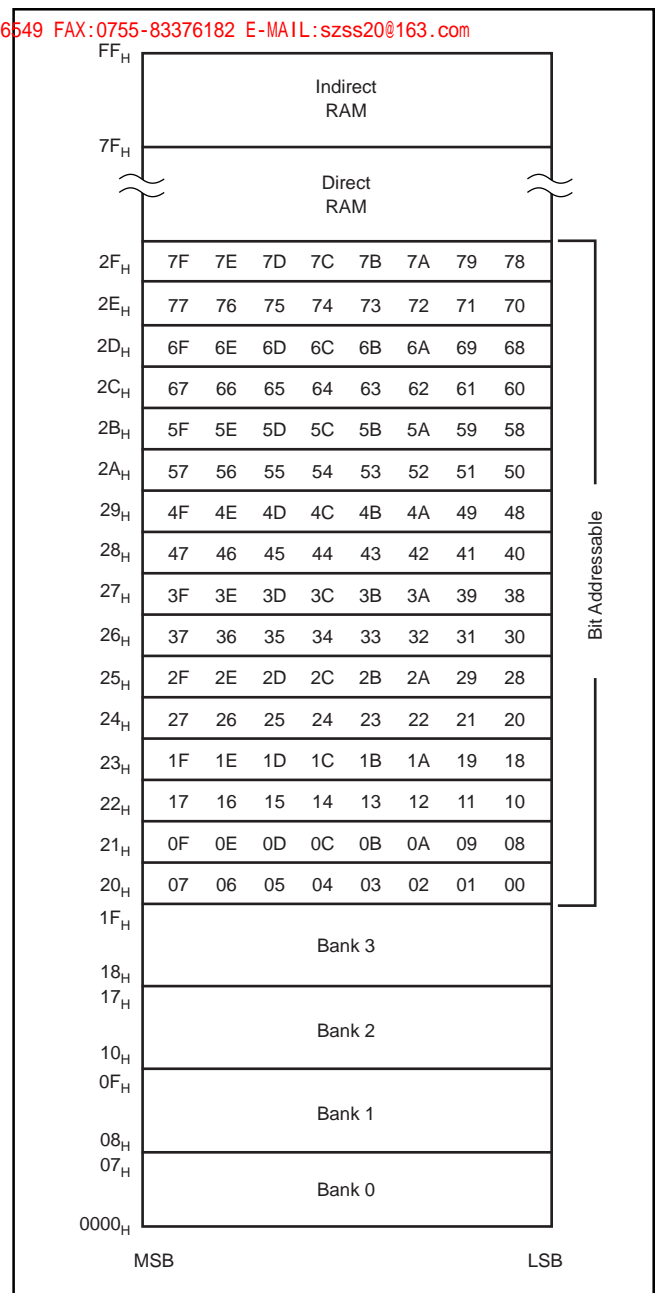

FIGURE 10. Scratchpad Register Addressing.

External Program Memory and external Data Memory may be combined if desired by applying the  $\overline{RD}$  and  $\overline{PSEN}$  signals to the inputs of an AND gate and using the output of the gate as the read strobe to the external Program/Data Memory.

Program fetches from external Program Memory always use a 16-bit address. Accesses to external Data Memory can use either a 16-bit address (MOVX @ DPTR) or an 8-bit address (MOVX @ R<sub>i</sub>).

If Port 2 is selected for external memory use (HCR1, bit 0), it can not be used as a general-purpose I/O. This bit (or Bit 1 of HCR1) also forces bits P3.6 and P3.7 to be used for  $\overline{WR}$  and  $\overline{RD}$  instead of I/O. Port 2, P3.6, and P3.7 should all be written to '1'.

If an 8-bit address is being used (MOVX at R<sub>i</sub>), the contents of the MPAGE (92<sub>H</sub>) SFR remain at the Port 2 pins throughout the external memory cycle. This will facilitate paging.

In any case, the low byte of the address is time-multiplexed with the data byte on Port 0. The ADDR/DATA signals use CMOS drivers in the Port 0, Port2,  $\overline{WR}$ , and  $\overline{RD}$  output buffers. Thus, in this application the Port 0 pins are not open-drain outputs, and do not require external pull-ups for high-speed access. Signal ALE (Address Latch Enable) should be used to capture the address byte into an external latch. The address byte is valid at the negative transition of ALE. Then, in a write cycle, the data byte to be written appears on Port 0 just before  $\overline{WR}$  is activated, and remains there until after  $\overline{WR}$  is deactivated. In a read cycle, the incoming byte is accepted at Port 0 just before the read strobe is deactivated.

The function of Port 0 and Port 2 is selected in Hardware Configuration Register 1. This can only be changed during the Flash Program mode. There is no conflict in the use of these registers; they will either be used as general-purpose I/O or for external memory access. The default state is for Port 0 and Port 2 to be used as general-purpose I/O. If an external memory access is attempted when they are configured as general-purpose I/O, the values of Port 0 and Port 2 will not be affected.

External Program Memory is accessed under two conditions:

- 1) Whenever signal  $\overline{EA}$  is active; or
- 2) Whenever the Program Counter (PC) contains a number that is outside of the internal Program Memory address range.

If Port 2 is selected for external memory, all 8 bits of Port 2, as well as P3.6 and P3.7, are dedicated to an output function and may not be used for general-purpose I/O. During external program fetches, Port 2 outputs the high byte of the PC.

### Programming Flash Memory

There are four sections of Flash Memory for programming.

1. 128 configuration bytes.
2. Reset sector (4kB) (not to be confused with the 2kB Boot ROM).
3. Program Memory.
4. Data Memory.

### Boot Rom

There is a 2kB Boot ROM that controls operation during serial or parallel programming. Additionally, the Boot ROM routines can be accessed during the user mode if it is enabled. When enabled, the Boot ROM routines will be located at memory addresses  $F800_H$ - $FFFF_H$  during user mode. In program mode the Boot ROM is located in the first 2kB of Program Memory.

### Flash Programming Mode

There are two programming modes: parallel and serial. The programming mode is selected by the state of the ALE and  $\overline{PSEN}$  signals during power-on reset. Serial programming mode is selected with  $\overline{PSEN} = 0$  and  $ALE = 1$ . The Parallel programming mode is selected with  $\overline{PSEN} = 1$  and  $ALE = 0$ . If they are both HIGH, the MSC1210 will operate in normal user mode. Both signals LOW is a reserved mode and is not defined. Programming mode is exited with a power-on reset signal and the normal mode selected.

The MSC1210 is shipped with Flash Memory erased (all 1's). Parallel programming methods typically involve a third-party programmer. Serial programming methods typically involve in-system programming. User Application mode allows Flash Program and Data Memory programming. The actual code for Flash programming can not execute from Flash. That code must execute from the Boot ROM or internal (Von Neuman) RAM.

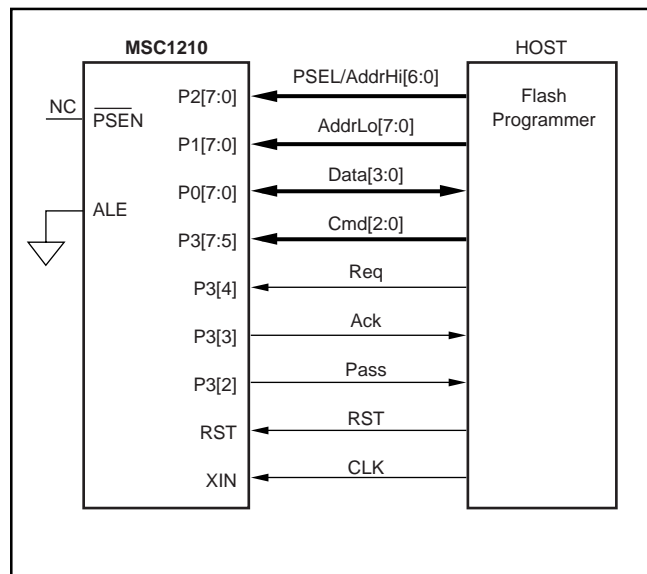

FIGURE 11. Parallel Programming Configuration.

### Hardware Configuration Memory

The 128 configuration bytes can only be written during the program mode. The bytes are accessed through SFR registers CADDR (SFR 93<sub>H</sub>) and CDATA (SFR 94<sub>H</sub>). Two of the configuration bytes control Flash partitioning and system control. If the security bit is set, these bits can not be changed except with a Mass Erase command that erases all of the Flash Memory including the 128 configuration bytes.

## Hardware Configuration Register 0 (HCR0) — Accessed Using SFR Registers CADDR and CDATA.

	bit 7	bit 6	bit 5	bit 4	bit 3	bit 2	bit 1	bit 0
FADDR 7F <sub>H</sub>	EPMA	PML	RSL	EBR	EWDR	DFSEL2	DFSEL1	DFSEL0

For access to this register during normal operation, refer to the register descriptions for CADDR and CDATA.

### **EPMA Enable Programming Memory Access (Security Bit).**

bit 7 0: After reset in programming modes, Flash Memory can not be read or written.  
1: Fully Accessible (default)

### **PML Program Memory Lock. (PML has Priority Over RSL)**

bit 6 0: Enable all Flash Programming Modes in program mode, can be written in UAM.  
1: Enable read only for program mode, can't be written in UAM (default).

### **RSL Reset Sector Lock.**

bit 5 0: Enable Reset Sector Writing  
1: Enable Read Only Mode for Reset Sector (4kB) (default)

### **EBR Enable Boot Rom. Boot Rom is 2kB of code located in ROM, not to be confused with the 4kB Boot Sector located in Flash Memory.**

bit 4 0: Disable Internal Boot Rom  
1: Enable Internal Boot Rom (default)

### **EWDR Enable Watchdog Reset.**

bit 3 0: Disable Watchdog Reset  
1: Enable Watchdog Reset (default)

### **DFSEL Data Flash Memory Size. (see Table II)**

bits 2-0 000: Reserved  
001: 32kB, 16kB, 8kB, or 4kB Data Flash Memory  
010: 16kB, 8kB, or 4kB Data Flash Memory  
011: 8kB or 4kB Data Flash Memory  
100: 4kB Data Flash Memory  
101: 2kB Data Flash Memory  
110: 1kB Data Flash Memory  
111: No Data Flash Memory (default)

The reset sector can be used to provide another method of Flash Memory programming. This will allow Program Memory updates without changing the jumpers for in-circuit code updates or program development. The code in this boot sector would then provide the monitor and programming routines with the ability to jump into the main Flash code when programming is finished.

## Hardware Configuration Register 1 (HCR1)

SUNSTAR 传感与控制 <http://www.sensor-ic.com/> TEL:0755-83376549 FAX:0755-83376182 E-MAIL:szss20@163.com

	7	6	5	4	3	2	1	0
FADDR 7E <sub>H</sub>	DBLSEL1	DBLSEL0	ABLSEL1	ABLSEL0	DAB	DDB	EGP0	EGP23

For access to this register during normal operation, refer to the register descriptions for CADDR and CDATA.

### DBLSEL Digital Brownout Level Select

bits 7-6 00: 4.5V  
01: 4.2V  
10: 2.7V  
11: 2.5V (default)

### ABLSEL Analog Brownout Level Select

bits 5-4 00: 4.5V  
01: 4.2V  
10: 2.7V  
11: 2.5V (default)

### DAB Disable Analog Power-Supply Brownout Detection

bit 3 0: Enable Analog Brownout Detection  
1: Disable Analog Brownout Detection (default)

### DDB Disable Digital Power-Supply Brownout Detection

bit 2 0: Enable Digital Brownout Detection  
1: Disable Digital Brownout Detection (default)

### EGP0 Enable General-Purpose I/O for Port 0

bit 1 0: Port 0 is Used for External Memory, P3.6 and P3.7 Used for  $\overline{WR}$  and  $\overline{RD}$ .  
1: Port 0 is Used as General-Purpose I/O (default)

### EGP23 Enable General-Purpose I/O for Ports 2 and 3

bit 0 0: Port 2 is Used for External Memory, P3.6 and P3.7 Used for  $\overline{WR}$  and  $\overline{RD}$ .  
1: Port 2 and Port3 are Used as General-Purpose I/O (default)

## Configuration Memory Programming

Certain key functions such as Brownout Reset and Watchdog Timer are controlled by the hardware configuration bits. These bits are nonvolatile and can only be changed through serial and parallel programming. Other peripheral control and status functions, such as ADC configuration timer setup, and Flash control are controlled through the SFRs.

**SFR Definition (Boldface is unique to the MSC1210xx)**

SUNSTAR自动化 http://www.sensor-ic.com/ TEL: 0755-83376549 FAX: 0755-83376182 E-MAIL: szss20@163.com

ADDRESS	REGISTER	BIT 7	BIT 6	BIT 5	BIT 4	BIT 3	BIT 2	BIT 1	BIT 0	RESET VALUES	
80 <sub>H</sub>	P0	P0.7	P0.6	P0.5	P0.4	P0.3	P0.2	P0.1	P0.0	FF <sub>H</sub>	
81 <sub>H</sub>	SP									07 <sub>H</sub>	
82 <sub>H</sub>	DPL0									00 <sub>H</sub>	
83 <sub>H</sub>	DPH0									00 <sub>H</sub>	
<b>84<sub>H</sub></b>	<b>DPL1</b>									<b>00<sub>H</sub></b>	
<b>85<sub>H</sub></b>	<b>DPH1</b>									<b>00<sub>H</sub></b>	
<b>86<sub>H</sub></b>	<b>DPS</b>	<b>0</b>	<b>0</b>	<b>0</b>	<b>0</b>	<b>0</b>	<b>0</b>	<b>0</b>	<b>SEL</b>	<b>00<sub>H</sub></b>	
<b>87<sub>H</sub></b>	<b>PCON</b>	<b>SMOD0</b>	<b>0</b>	<b>1</b>	<b>1</b>	<b>GF1</b>	<b>GF0</b>	<b>STOP</b>	<b>IDLE</b>	<b>30<sub>H</sub></b>	
88 <sub>H</sub>	TCON	TF1	TR1	TF0	TR0	IE1	IT1 IE0		IT0	00 <sub>H</sub>	
89 <sub>H</sub>	TMOD	-----Timer 1 -----				-----Timer 0 -----					00 <sub>H</sub>
		GATE	C $\bar{T}$	M1	M0	GATE	C $\bar{T}$	M1	M0		
8A <sub>H</sub>	TL0									00 <sub>H</sub>	
8B <sub>H</sub>	TL1									00 <sub>H</sub>	
8C <sub>H</sub>	TH0									00 <sub>H</sub>	
8D <sub>H</sub>	TH1									00 <sub>H</sub>	
<b>8E<sub>H</sub></b>	<b>CKCON</b>	<b>0</b>	<b>0</b>	<b>T2M</b>	<b>T1M</b>	<b>T0M</b>	<b>MD2</b>	<b>MD1</b>	<b>MD0</b>	<b>01<sub>H</sub></b>	
<b>8F<sub>H</sub></b>	<b>MWS</b>	<b>0</b>	<b>0</b>	<b>0</b>	<b>0</b>	<b>0</b>	<b>0</b>	<b>0</b>	<b>MXWS</b>	<b>00<sub>H</sub></b>	
90 <sub>H</sub>	P1	P1.7 INT5/SCK	P1.6 INT4/MISO	P1.5 INT3/MOSI	P1.4 INT2/SS	P1.3 TXD1	P1.2 RXD1	P1.1 T2EX	P1.0 T2	FF <sub>H</sub>	
91 <sub>H</sub>	EXIF	IE5	IE4	IE3	IE2	1	0	0	0	08 <sub>H</sub>	
<b>92<sub>H</sub></b>	<b>MPAGE</b>									<b>00<sub>H</sub></b>	
<b>93<sub>H</sub></b>	<b>CADDR</b>									<b>00<sub>H</sub></b>	
<b>94<sub>H</sub></b>	<b>CDATA</b>									<b>00<sub>H</sub></b>	
<b>95<sub>H</sub></b>	<b>MCON</b>	<b>BPSEL</b>	<b>0</b>	<b>0</b>					<b>RAMMAP</b>	<b>00<sub>H</sub></b>	
96 <sub>H</sub>											
97 <sub>H</sub>											
98 <sub>H</sub>	SCON0	SM0_0	SM1_0	SM2_0	REN_0	TB8_0	RB8_0	TL_0	RI_0	00 <sub>H</sub>	
99 <sub>H</sub>	SBUF0									00 <sub>H</sub>	
<b>9A<sub>H</sub></b>	<b>SPICON</b>	<b>SCLK2</b>	<b>SCLK1</b>	<b>SCLK0</b>	<b>FIFO</b>	<b>ORDER</b>	<b>MSTR</b>	<b>CPHA</b>	<b>CPOL</b>	<b>00<sub>H</sub></b>	
<b>9B<sub>H</sub></b>	<b>SPIDATA</b>									<b>00<sub>H</sub></b>	
<b>9C<sub>H</sub></b>	<b>SPIRCON</b>	<b>RXCNT7</b> <b>RXFLUSH</b>	<b>RXCNT6</b>	<b>RXCNT5</b>	<b>RXCNT4</b>	<b>RXCNT3</b>	<b>RXCNT2</b> <b>RXIRQ2</b>	<b>RXCNT1</b> <b>RXIRQ1</b>	<b>RXCNT0</b> <b>RXIRQ0</b>	<b>00<sub>H</sub></b>	
<b>9D<sub>H</sub></b>	<b>SPITCON</b>	<b>TXCNT7</b> <b>TXFLUSH</b>	<b>TXCNT6</b>	<b>TXCNT5</b> <b>CLK_EN</b>	<b>TXCNT4</b> <b>DRV_DLY</b>	<b>TXCNT3</b> <b>DRV_EN</b>	<b>TXCNT2</b> <b>TXIRQ2</b>	<b>TXCNT1</b> <b>TXIRQ1</b>	<b>TXCNT0</b> <b>TXIRQ0</b>	<b>00<sub>H</sub></b>	
<b>9E<sub>H</sub></b>	<b>SPISTART</b>	<b>1</b>								<b>80<sub>H</sub></b>	
<b>9F<sub>H</sub></b>	<b>SPIEND</b>	<b>1</b>								<b>80<sub>H</sub></b>	
A0 <sub>H</sub>	P2	P2.7	P2.6	P2.5	P2.4	P2.3	P2.2	P2.1	P2.0	FF <sub>H</sub>	
<b>A1<sub>H</sub></b>	<b>PWMCON</b>			<b>PPOL</b>	<b>PWMSEL</b>	<b>SPDSEL</b>	<b>TPCNTL2</b>	<b>TPCNTL1</b>	<b>TPCNTL0</b>	<b>00<sub>H</sub></b>	
<b>A2<sub>H</sub></b>	<b>PWMLOW</b>	<b>PWM7</b>	<b>PWM6</b>	<b>PWM5</b>	<b>PWM4</b>	<b>PWM3</b>	<b>PWM2</b>	<b>PWM1</b>	<b>PWM0</b>	<b>00<sub>H</sub></b>	
<b>A3<sub>H</sub></b>	<b>PWMHI</b>	<b>PWM15</b>	<b>PWM14</b>	<b>PWM13</b>	<b>PWM12</b>	<b>PWM11</b>	<b>PWM10</b>	<b>PWM9</b>	<b>PWM8</b>	<b>00<sub>H</sub></b>	
A4 <sub>H</sub>											
<b>A5<sub>H</sub></b>	<b>PAI</b>	<b>0</b>	<b>0</b>	<b>0</b>	<b>0</b>	<b>PIP.3</b>	<b>PIP.2</b>	<b>PIP.1</b>	<b>PIP.0</b>	<b>00<sub>H</sub></b>	
<b>A6<sub>H</sub></b>	<b>AIE</b>	<b>ESEC</b>	<b>ESUM</b>	<b>EADC</b>	<b>EMSEC</b>	<b>ESPIT</b>	<b>ESPIR</b>	<b>EALV</b>	<b>EDLVB</b>	<b>00<sub>H</sub></b>	
<b>A7<sub>H</sub></b>	<b>AISTAT</b>	<b>SEC</b>	<b>SUM</b>	<b>ADC</b>	<b>MSEC</b>	<b>SPIT</b>	<b>SPIR</b>	<b>ALVD</b>	<b>DLVD</b>	<b>00<sub>H</sub></b>	
A8 <sub>H</sub>	IE	EA	ES1	ET2	ES0	ET1	EX1	ET0	EX0	00 <sub>H</sub>	
<b>A9<sub>H</sub></b>	<b>BPCON</b>	<b>BP</b>	<b>0</b>	<b>0</b>	<b>0</b>	<b>0</b>	<b>0</b>	<b>PMSEL</b>	<b>EPB</b>	<b>00<sub>H</sub></b>	
<b>AA<sub>H</sub></b>	<b>BPL</b>									<b>00<sub>H</sub></b>	
<b>AB<sub>H</sub></b>	<b>BPH</b>									<b>00<sub>H</sub></b>	
<b>AC<sub>H</sub></b>	<b>P0DDR1</b>	<b>P03H</b>	<b>P03L</b>	<b>P02H</b>	<b>P02L</b>	<b>P01H</b>	<b>P01L</b>	<b>P00H</b>	<b>P00L</b>	<b>00<sub>H</sub></b>	
<b>AD<sub>H</sub></b>	<b>P0DDRH</b>	<b>P07H</b>	<b>P07L</b>	<b>P06H</b>	<b>P06L</b>	<b>P05H</b>	<b>P05L</b>	<b>P04H</b>	<b>P04L</b>	<b>00<sub>H</sub></b>	
<b>AE<sub>H</sub></b>	<b>P1DDR1</b>	<b>P13H</b>	<b>P13L</b>	<b>P12H</b>	<b>P12L</b>	<b>P11H</b>	<b>P11L</b>	<b>P10H</b>	<b>P10L</b>	<b>00<sub>H</sub></b>	
<b>AF<sub>H</sub></b>	<b>P1DDRH</b>	<b>P17H</b>	<b>P17L</b>	<b>P16H</b>	<b>P16L</b>	<b>P15H</b>	<b>P15L</b>	<b>P14H</b>	<b>P14L</b>	<b>00<sub>H</sub></b>	
B0 <sub>H</sub>	P3	P3.7	P3.6	P3.5	P3.4	P3.3	P3.2	P3.1	P3.0	FF <sub>H</sub>	
<b>B1<sub>H</sub></b>	<b>P2DDR1</b>	<b>P23H</b>	<b>P23L</b>	<b>P22H</b>	<b>P22L</b>	<b>P21H</b>	<b>P21L</b>	<b>P20H</b>	<b>P20L</b>	<b>00<sub>H</sub></b>	
<b>B2<sub>H</sub></b>	<b>P2DDRH</b>	<b>P27H</b>	<b>P27L</b>	<b>P26H</b>	<b>P26L</b>	<b>P25H</b>	<b>P25L</b>	<b>P24H</b>	<b>P24L</b>	<b>00<sub>H</sub></b>	
<b>B3<sub>H</sub></b>	<b>P3DDR1</b>	<b>P33H</b>	<b>P33L</b>	<b>P32H</b>	<b>P32L</b>	<b>P31H</b>	<b>P31L</b>	<b>P30H</b>	<b>P30L</b>	<b>00<sub>H</sub></b>	
<b>B4<sub>H</sub></b>	<b>P3DDRH</b>	<b>P37H</b>	<b>P37L</b>	<b>P36H</b>	<b>P36L</b>	<b>P35H</b>	<b>P35L</b>	<b>P34H</b>	<b>P34L</b>	<b>00<sub>H</sub></b>	
B5 <sub>H</sub>											
B6 <sub>H</sub>											
B7 <sub>H</sub>											
B8 <sub>H</sub>	IP	1	PS1	PT2	PS0	PT1	PX1	PT0	PX0	80 <sub>H</sub>	
B9 <sub>H</sub>											
BA <sub>H</sub>											
BB <sub>H</sub>											
BC <sub>H</sub>											
BD <sub>H</sub>											
BE <sub>H</sub>											
BF <sub>H</sub>											

**SFR Definition (Cont.)**

SUNSTAR 传感与控制 <http://www.sensor-ic.com/> TEL:0755-83376549 FAX:0755-83376182 E-MAIL:szsss20@163.com

ADDRESS	REGISTER	BIT 7	BIT 6	BIT 5	BIT 4	BIT 3	BIT 2	BIT 1	BIT 0	RESET VALUES
C0 <sub>H</sub>	SCON1	SM0_1	SM1_1	SM2_1	REN_1	TB8_1	RB8_1	TL_1	RI_1	00 <sub>H</sub>
C1 <sub>H</sub>	SBUF1									00 <sub>H</sub>
C2 <sub>H</sub>										
C3 <sub>H</sub>										
C4 <sub>H</sub>										
C5 <sub>H</sub>										
C6 <sub>H</sub>	EWU						EWUWDT	EWUEX1	EWUEX0	00 <sub>H</sub>
C7 <sub>H</sub>										
C8 <sub>H</sub>	T2CON	TF2	EXF2	RCLK	TCLK	EXEN2	TR2	C/T2	CP/RL2	00 <sub>H</sub>
C9 <sub>H</sub>										
CA <sub>H</sub>	RCAP2L									00 <sub>H</sub>
CB <sub>H</sub>	RCAP2H									00 <sub>H</sub>
CC <sub>H</sub>	TL2									00 <sub>H</sub>
CD <sub>H</sub>	TH2									00 <sub>H</sub>
CE <sub>H</sub>										
CF <sub>H</sub>										
D0 <sub>H</sub>	PSW	CY	AC	F0	RS1	RS0	OV	F1	P	00 <sub>H</sub>
D1 <sub>H</sub>	OCL								LSB	00 <sub>H</sub>
D2 <sub>H</sub>	OCM									00 <sub>H</sub>
D3 <sub>H</sub>	OCH	MSB								00 <sub>H</sub>
D4 <sub>H</sub>	GCL								LSB	5A <sub>H</sub>
D5 <sub>H</sub>	GCM									EC <sub>H</sub>
D6 <sub>H</sub>	GCH	MSB								5F <sub>H</sub>
D7 <sub>H</sub>	ADMUX	INP3	INP2	INP1	INP0	INN3	INN2	INN1	INN0	01 <sub>H</sub>
D8 <sub>H</sub>	EICON	SMOD1	1	EAI	AI	WDTI	0	0	0	40 <sub>H</sub>
D9 <sub>H</sub>	ADRESL								LSB	00 <sub>H</sub>
DA <sub>H</sub>	ADRESM									00 <sub>H</sub>
DB <sub>H</sub>	ADRESH	MSB								00 <sub>H</sub>
DC <sub>H</sub>	ADCON0	—	BOD	EVREF	VREFH	EBUF	PGA2	PGA1	PGA0	30 <sub>H</sub>
DD <sub>H</sub>	ADCON1	—	POL	SM1	SM0	—	CAL2	CAL1	CAL0	x000 0000 <sub>B</sub>
DE <sub>H</sub>	ADCON2	DR7	DR6	DR5	DR4	DR3	DR2	DR1	DR0	1B <sub>H</sub>
DF <sub>H</sub>	ADCON3	0	0	0	0	0	DR10	DR9	DR8	06 <sub>H</sub>
E0 <sub>H</sub>	ACC	ACC.7	ACC.6	ACC.5	ACC.4	ACC.3	ACC.2	ACC.1	ACC.0	00 <sub>H</sub>
E1 <sub>H</sub>	SSCON	SSCON1	SSCON0	SCNT2	SCNT1	SCNT0	SHF2	SHF1	SHF0	00 <sub>H</sub>
E2 <sub>H</sub>	SUMR0									00 <sub>H</sub>
E3 <sub>H</sub>	SUMR1									00 <sub>H</sub>
E4 <sub>H</sub>	SUMR2									00 <sub>H</sub>
E5 <sub>H</sub>	SUMR3									00 <sub>H</sub>
E6 <sub>H</sub>	ODAC									00 <sub>H</sub>
E7 <sub>H</sub>	LVDCON	ALVDIS	ALVD2	ALVD1	ALVD0	DLVDIS	DLVD2	DLVD1	DLVD0	00 <sub>H</sub>
E8 <sub>H</sub>	EIE	1	1	1	EWDI	EX5	EX4	EX3	EX2	E0 <sub>H</sub>
E9 <sub>H</sub>	HWPC0									
EA <sub>H</sub>	HWPC1									
EB <sub>H</sub>	Reserved									00 <sub>H</sub>
EC <sub>H</sub>	Reserved									xx <sub>H</sub>
ED <sub>H</sub>	Reserved									00 <sub>H</sub>
EE <sub>H</sub>	FMCON	0	PGERA	0	FRCM	0	BUSY	1	0	02 <sub>H</sub>
EF <sub>H</sub>	FTCON	FER3	FER2	FER1	FER0	FWR3	FWR2	FWR1	FWR0	A5 <sub>H</sub>
F0 <sub>H</sub>	B	B.7	B.6	B.5	B.4	B.3	B.2	B.1	B.0	00 <sub>H</sub>
F1 <sub>H</sub>	PDCON	0	0	0	PDPWM	PDAD	PDSDT	PDST	PDSP1	1F <sub>H</sub>
F2 <sub>H</sub>	PASEL	0	0	PSEN2	PSEN1	PSEN0	0	ALE1	ALE0	00 <sub>H</sub>
F3 <sub>H</sub>										
F4 <sub>H</sub>										
F5 <sub>H</sub>										
F6 <sub>H</sub>	ACLK	0	0	0	FREQ4	FREQ3	FREQ2	FREQ1	FREQ0	03 <sub>H</sub>
F7 <sub>H</sub>	SRST	0	0	0	0	0	0	0	RSTREQ	00 <sub>H</sub>
F8 <sub>H</sub>	EIP	1	1	1	PWDI	PX5	PX4	PX3	PX2	E0 <sub>H</sub>
F9 <sub>H</sub>	SECINT	WRT	SECINT6	SECINT5	SECINT4	SECINT3	SECINT2	SECINT1	SECINT0	7F <sub>H</sub>
FA <sub>H</sub>	MSINT	WRT	MSINT6	MSINT5	MSINT4	MSINT3	MSINT2	MSINT1	MSINT0	7F <sub>H</sub>
FB <sub>H</sub>	USEC	0	0	0	FREQ4	FREQ3	FREQ2	FREQ1	FREQ0	03 <sub>H</sub>
FC <sub>H</sub>	MSECL									9F <sub>H</sub>
FD <sub>H</sub>	MSECH									0F <sub>H</sub>
FE <sub>H</sub>	HMSEC									63 <sub>H</sub>
FF <sub>H</sub>	WDTCN	EWDT	DWDT	RWDT	WDCNT4	WDCNT3	WDCNT2	WDCNT1	WDCNT0	00 <sub>H</sub>

## Port 0 (P0)

SUNSTAR传感与控制 <http://www.sensor-ic.com/> TEL:0755-83376549 FAX:0755-83376182 E-MAIL:szss20@163.com

	7	6	5	4	3	2	1	0	Reset Value
SFR 80 <sub>H</sub>	P0.7	P0.6	P0.5	P0.4	P0.3	P0.2	P0.1	P0.0	FF <sub>H</sub>

**P0.7-0** bits 7-0 **Port 0.** This port functions as a multiplexed address/data bus during external memory access, and as a general-purpose I/O port when external memory access is not needed. During external memory cycles, this port will contain the LSB of the address when ALE is HIGH, and Data when ALE is LOW. When used as a general-purpose I/O, this port drive is selected by P0DDR<sub>L</sub> and P0DDR<sub>H</sub> (AC<sub>H</sub>, AD<sub>H</sub>). Whether Port 0 is used as general-purpose I/O or for external memory access is determined by the Flash Configuration Register (HCR1.1) (see SFR CADDR 93<sub>H</sub>).

## Stack Pointer (SP)

	7	6	5	4	3	2	1	0	Reset Value
SFR 81 <sub>H</sub>	SP.7	SP.6	SP.5	SP.4	SP.3	SP.2	SP.1	SP.0	07 <sub>H</sub>

**SP.7-0** bits 7-0 **Stack Pointer.** The stack pointer identifies the location where the stack will begin. The stack pointer is incremented before every PUSH or CALL operation and decremented after each POP or RET/RETI. This register defaults to 07<sub>H</sub> after reset.

## Data Pointer Low 0 (DPL0)

	7	6	5	4	3	2	1	0	Reset Value
SFR 82 <sub>H</sub>	DPL0.7	DPL0.6	DPL0.5	DPL0.4	DPL0.3	DPL0.2	DPL0.1	DPL0.0	00 <sub>H</sub>

**DPL.7-0** bits 7-0 **Data Pointer Low 0.** This register is the low byte of the standard 8051 16-bit data pointer. DPL0 and DPH0 are used to point to non-scratchpad data RAM. The current data pointer is selected by DPS (SFR 86<sub>H</sub>).

## Data Pointer High 0 (DPH0)

	7	6	5	4	3	2	1	0	Reset Value
SFR 83 <sub>H</sub>	DPH0.7	DPH0.6	DPH0.5	DPH0.4	DPH0.3	DPH0.2	DPH0.1	DPH0.0	00 <sub>H</sub>

**DPH.7-0** bits 7-0 **Data Pointer High 0.** This register is the high byte of the standard 8051 16-bit data pointer. DPL0 and DPH0 are used to point to non-scratchpad data RAM. The current data pointer is selected by DPS (SFR 86<sub>H</sub>).

## Data Pointer Low 1 (DPL1)

	7	6	5	4	3	2	1	0	Reset Value
SFR 84 <sub>H</sub>	DPL1.7	DPL1.6	DPL1.5	DPL1.4	DPL1.3	DPL1.2	DPL1.1	DPL1.0	00 <sub>H</sub>

**DPL1.7-0** bits 7-0 **Data Pointer Low 1.** This register is the low byte of the auxiliary 16-bit data pointer. When the SEL bit (DPS.0) (SFR 86<sub>H</sub>) is set, DPL1 and DPH1 are used in place of DPL0 and DPH0 during DPTR operations.

## Data Pointer High 1 (DPH1)

	7	6	5	4	3	2	1	0	Reset Value
SFR 85 <sub>H</sub>	DPH1.7	DPH1.6	DPH1.5	DPH1.4	DPH1.3	DPH1.2	DPH1.1	DPH1.0	00 <sub>H</sub>

**DPH1.7-0** bits 7-0 **Data Pointer High 1.** This register is the high byte of the auxiliary 16-bit data pointer. When the SEL bit (DPS.0) (SFR 86<sub>H</sub>) is set, DPL1 and DPH1 are used in place of DPL0 and DPH0 during DPTR operations.

## Data Pointer Select (DPS)

	7	6	5	4	3	2	1	0	Reset Value
SFR 86 <sub>H</sub>	0	0	0	0	0	0	0	SEL	00 <sub>H</sub>

**SEL** bit 0 **Data Pointer Select.** This bit selects the active data pointer.  
0: Instructions that use the DPTR will use DPL0 and DPH0.  
1: Instructions that use the DPTR will use DPL1 and DPH1.

## Power Control (PCON)

SUNSTAR传感与控制 <http://www.sensor-ic.com/> TEL:0755-83376549 FAX:0755-83376182 E-MAIL:szss20@163.com

	7	6	5	4	3	2	1	0	Reset Value
SFR 87 <sub>H</sub>	SMOD0	0	1	1	GF1	GF0	STOP	IDLE	30 <sub>H</sub>

**SMOD0 Serial Port 0 Baud Rate Doubler Enable.** The serial baud rate doubling function for Serial Port 0.

- bit 7  
0: Serial Port 0 baud rate will be a standard baud rate.  
1: Serial Port 0 baud rate will be double that defined by baud rate generation equation.

**GF1 General-Purpose User Flag 1.** This is a general-purpose flag for software control.

bit 3

**GF0 General-Purpose User Flag 0.** This is a general-purpose flag for software control.

bit 2

**STOP Stop Mode Select.** Setting this bit will stop program execution, halt the oscillator and internal timers, and place the CPU in a low-power mode. This bit will always read as a 0. Exit with RESET.

bit 1

**IDLE Idle Mode Select.** Setting this bit will stop program execution but leave the external interrupt 1, 0, auxiliary interrupts, and PWM are active. This bit will always be read as a 0. Exit with AI and EWU (C6<sub>H</sub>) interrupts.

bit 0

## Timer/Counter Control (TCON)

	7	6	5	4	3	2	1	0	Reset Value
SFR 88 <sub>H</sub>	TF1	TR1	TF0	TR0	IE1	IT1	IE0	IT0	00 <sub>H</sub>

**TF1 Timer 1 Overflow Flag.** This bit indicates when Timer 1 overflows its maximum count as defined by the current mode. This bit can be cleared by software and is automatically cleared when the CPU vectors to the Timer 1 interrupt service routine.

bit 7

- 0: No Timer 1 overflow has been detected.  
1: Timer 1 has overflowed its maximum count.

**TR1 Timer 1 Run Control.** This bit enables/disables the operation of Timer 0. Halting this timer will preserve the current bit 6 count in TH1, TL1.

bit 6

- 0: Timer is halted.  
1: Timer is enabled.

**TF0 Timer 0 Overflow Flag.** This bit indicates when Timer 0 overflows its maximum count as defined by the current mode. This bit can be cleared by software and is automatically cleared when the CPU vectors to the Timer 0 interrupt service routine.

bit 5

- 0: No Timer 0 overflow has been detected.  
1: Timer 0 has overflowed its maximum count.

**TR0 Timer 0 Run Control.** This bit enables/disables the operation of Timer 0. Halting this timer will preserve the current count in TH0, TL0.

bit 4

- 0: Timer is halted.  
1: Timer is enabled.

**IE1 Interrupt 1 Edge Detect.** This bit is set when an edge/level of the type defined by IT1 is detected. If IT1 = 1, this bit will remain set until cleared in software or the start of the External Interrupt 1 service routine. If IT1 = 0, this bit will inversely reflect the state of the  $\overline{\text{INT1}}$  pin.

bit 3

**IT1 Interrupt 1 Type Select.** This bit selects whether the  $\overline{\text{INT1}}$  pin will detect edge or level triggered interrupts.

bit 2

- 0:  $\overline{\text{INT1}}$  is level triggered.  
1:  $\overline{\text{INT1}}$  is edge triggered.

**IE0 Interrupt 0 Edge Detect.** This bit is set when an edge/level of the type defined by IT0 is detected. If IT0 = 1, this bit will remain set until cleared in software or the start of the External Interrupt 0 service routine. If IT0 = 0, this bit will inversely reflect the state of the  $\overline{\text{INT0}}$  pin.

bit 3

**IT0 Interrupt 0 Type Select.** This bit selects whether the  $\overline{\text{INT0}}$  pin will detect edge or level triggered interrupts.

bit 2

- 0:  $\overline{\text{INT0}}$  is level triggered.  
1:  $\overline{\text{INT0}}$  is edge triggered.

## Timer Mode Control (TMOD)

SUNSTAR传感与控制 <http://www.sensor-ic.com/> TEL:0755-83376549 FAX:0755-83376182 E-MAIL:szss20@163.com

	7	6	5	4	3	2	1	0	Reset Value 00 <sub>H</sub>
	TIMER 1				TIMER 0				
SFR 89 <sub>H</sub>	GATE	C $\bar{T}$	M1	M0	GATE	C $\bar{T}$	M1	M0	

**GATE** **Timer 1 Gate Control.** This bit enables/disables the ability of Timer 1 to increment.  
 bit 7 0: Timer 1 will clock when TR1 = 1, regardless of the state of pin  $\overline{INT1}$ .  
 1: Timer 1 will clock only when TR1 = 1 and pin  $\overline{INT1}$  = 1.

**C $\bar{T}$**  **Timer 1 Counter/Timer Select.**  
 bit 6 0: Timer is incremented by internal clocks.  
 1: Timer is incremented by pulses on T1 pin when TR1 (TCON.6, SFR 88<sub>H</sub>) is 1.

**M1, M0** **Timer 1 Mode Select.** These bits select the operating mode of Timer 1.  
 bits 5-4

M1	M0	MODE
0	0	Mode 0: 8-bit counter with 5-bit prescale.
0	1	Mode 1: 16 bits.
1	0	Mode 2: 8-bit counter with auto reload.
1	1	Mode 3: Timer 1 is halted, but holds its count.

**GATE** **Timer 0 Gate Control.** This bit enables/disables the ability of Timer 0 to increment.  
 bit 3 0: Timer 0 will clock when TR0 = 1, regardless of the state of pin  $\overline{INT0}$  (software control).  
 1: Timer 0 will clock only when TR0 = 1 and pin  $\overline{INT0}$  = 1 (hardware control).

**C $\bar{T}$**  **Timer 0 Counter/Timer Select.**  
 bit 2 0: Timer is incremented by internal clocks.  
 1: Timer is incremented by pulses on pin T0 when TR0 (TCON.4, SFR 88<sub>H</sub>) is 1.

**M1, M0** **Timer 0 Mode Select.** These bits select the operating mode of Timer 0.  
 bits 1-0

M1	M0	MODE
0	0	Mode 0: 8-bit counter with 5-bit prescale.
0	1	Mode 1: 16 bits.
1	0	Mode 2: 8-bit counter with auto reload.
1	1	Mode 3: Timer 1 is halted, but holds its count.

## Timer 0 LSB (TL0)

	7	6	5	4	3	2	1	0	Reset Value
SFR 8A <sub>H</sub>	TL0.7	TL0.6	TL0.5	TL0.4	TL0.3	TL0.2	TL0.1	TL0.0	00 <sub>H</sub>

TL0.7-0 **Timer 0 LSB.** This register contains the least significant byte of Timer 0.  
 bits 7-0

## Timer 1 LSB (TL1)

	7	6	5	4	3	2	1	0	Reset Value
SFR 8B <sub>H</sub>	TL1.7	TL1.6	TL1.5	TL1.4	TL1.3	TL1.2	TL1.1	TL1.0	00 <sub>H</sub>

TL1.7-0 **Timer 1 LSB.** This register contains the least significant byte of Timer 1.  
 bits 7-0

## Timer 0 MSB (TH0)

	7	6	5	4	3	2	1	0	Reset Value
SFR 8C <sub>H</sub>	TH0.7	TH0.6	TH0.5	TH0.4	TH0.3	TH0.2	TH0.1	TH0.0	00 <sub>H</sub>

TH0.7-0 **Timer 0 MSB.** This register contains the most significant byte of Timer 0.  
 bits 7-0

## Timer 1 MSB (TH1)

SUNSTAR传感与控制 <http://www.sensor-ic.com/> TEL:0755-83376549 FAX:0755-83376182 E-MAIL:szsss20@163.com

	7	6	5	4	3	2	1	0	Reset Value
SFR 8D <sub>H</sub>	TH1.7	TH1.6	TH1.5	TH1.4	TH1.3	TH1.2	TH1.1	TH1.0	00 <sub>H</sub>

**TH1.7-0** **Timer 1 MSB.** This register contains the most significant byte of Timer 1.  
bits 7-0

## Clock Control (CKCON)

	7	6	5	4	3	2	1	0	Reset Value
SFR 8E <sub>H</sub>	0	0	T2M	T1M	T0M	MD2	MD1	MD0	01 <sub>H</sub>

**T2M** **Timer 2 Clock Select.** This bit controls the division of the system clock that drives Timer 2. This bit has no effect when the timer is in baud rate generator or clock output modes. Clearing this bit to 0 maintains 80C32 compatibility. This bit has no effect on instruction cycle timing.

0: Timer 2 uses a divide by 12 of the crystal frequency.

1: Timer 2 uses a divide by 4 of the crystal frequency.

**T1M** **Timer 1 Clock Select.** This bit controls the division of the system clock that drives Timer 1. Clearing this bit to 0 maintains 8051 compatibility. This bit has no effect on instruction cycle timing.

0: Timer 1 uses a divide by 12 of the crystal frequency.

1: Timer 1 uses a divide by 4 of the crystal frequency.

**T0M** **Timer 0 Clock Select.** This bit controls the division of the system clock that drives Timer 0. Clearing this bit to 0 maintains 8051 compatibility. This bit has no effect on instruction cycle timing.

0: Timer 0 uses a divide by 12 of the crystal frequency.

1: Timer 0 uses a divide by 4 of the crystal frequency.

**MD2, MD1, MD0** **Stretch MOVX Select 2-0.** These bits select the time by which external MOVX cycles are to be stretched. This allows slower memory or peripherals to be accessed without using ports or manual software intervention. The  $\overline{RD}$  or  $\overline{WR}$  strobe will be stretched by the specified interval, which will be transparent to the software except for the increased time to execute the MOVX instruction. All internal MOVX instructions on devices containing MOVX SRAM are performed at the 2 instruction cycle rate.

MD2	MD1	MD0	STRETCH VALUE	MOVX DURATION	$\overline{RD}$ or $\overline{WR}$ STROBE WIDTH (SYS CLKs)	$\overline{RD}$ or $\overline{WR}$ STROBE WIDTH ( $\mu$ s) AT 12MHz
0	0	0	0	2 Instruction Cycles	2	0.167
0	0	1	1	3 Instruction Cycles (default)	4	0.333
0	1	0	2	4 Instruction Cycles	8	0.667
0	1	1	3	5 Instruction Cycles	12	1.000
1	0	0	4	6 Instruction Cycles	16	1.333
1	0	1	5	7 Instruction Cycles	20	1.667
1	1	0	6	8 Instruction Cycles	24	2.000
1	1	1	7	9 Instruction Cycles	28	2.333

## Memory Write Select (MWS)

	7	6	5	4	3	2	1	0	Reset Value
SFR 8F <sub>H</sub>	0	0	0	0	0	0	0	MXWS	00 <sub>H</sub>

**MXWS** **MOVX Write Select.** This allows writing to the internal Flash program memory.

0: No writes are allowed to the internal Flash program memory.

1: Writing is allowed to the internal Flash program memory, unless PML or RSL (HCR0) are on.

	7	6	5	4	3	2	1	0	Reset Value
SFR 90 <sub>H</sub>	P1.7 INT5/SCK	P1.6 INT4/MISO	P1.5 INT3/MOSI	P1.4 INT2/SS	P1.3 TXD1	P1.2 RXD1	P1.1 T2EX	P1.0 T2	FF <sub>H</sub>

**P1.7-0** bits 7-0 **General-Purpose I/O Port 1.** This register functions as a general-purpose I/O port. In addition, all the pins have an alternative function listed below. Each of the functions is controlled by several other SFRs. The associated Port 1 latch bit must contain a logic '1' before the pin can be used in its alternate function capacity. To use the alternate function, set the appropriate mode in P1DDRL (SFR AE<sub>H</sub>), P1DDRH (SFR AF<sub>H</sub>).

**INT5/SCK** bit 7 **External Interrupt 5.** A falling edge on this pin will cause an external interrupt 5 if enabled.  
**SPI Clock.** The master clock for SPI data transfers.

**INT4/MISO** bit 6 **External Interrupt 4.** A rising edge on this pin will cause an external interrupt 4 if enabled.  
**Master In Slave Out.** For SPI data transfers, this pin receives data for the master and transmits data from the slave.

**INT3/MOSI** bit 5 **External Interrupt 3.** A falling edge on this pin will cause an external interrupt 3 if enabled.  
**Master Out Slave In.** For SPI data transfers, this pin transmits master data and receives slave data.

**INT2/SS** bit 4 **External Interrupt 2.** A falling edge on this pin will cause an external interrupt 2 if enabled.  
**Slave Select.** During SPI operation, this pin provides the select signal for the slave device.

**TXD1** bit 3 **Serial Port 1 Transmit.** This pin transmits the serial Port 1 data in serial port modes 1, 2, 3, and emits the synchronizing clock in serial port mode 0.

**RXD1** bit 2 **Serial Port 1 Receive.** This pin receives the serial Port 1 data in serial port modes 1, 2, 3, and is a bidirectional data transfer pin in serial port mode 0.

**T2EX** bit 1 **Timer 2 Capture/Reload Trigger.** A 1 to 0 transition on this pin will cause the value in the T2 registers to be transferred into the capture registers if enabled by EXEN2 (T2CON.3, SFR C8<sub>H</sub>). When in auto-reload mode, a 1 to 0 transition on this pin will reload the Timer 2 registers with the value in RCAP2L and RCAP2H if enabled by EXEN2 (T2CON.3, SFR C8<sub>H</sub>).

**T2** bit 0 **Time 2 External Input.** A 1 to 0 transition on this pin will cause Timer 2 to increment or decrement depending on the timer configuration.

### External Interrupt Flag (EXIF)

	7	6	5	4	3	2	1	0	Reset Value
SFR 91 <sub>H</sub>	IE5	IE4	IE3	IE2	1	0	0	0	08 <sub>H</sub>

**IE5** bit 7 **External Interrupt 5 Flag.** This bit will be set when a falling edge is detected on INT5. This bit must be cleared manually by software. Setting this bit in software will cause an interrupt if enabled.

**IE4** bit 6 **External Interrupt 4 Flag.** This bit will be set when a rising edge is detected on INT4. This bit must be cleared manually by software. Setting this bit in software will cause an interrupt if enabled.

**IE3** bit 5 **External Interrupt 3 Flag.** This bit will be set when a falling edge is detected on INT3. This bit must be cleared manually by software. Setting this bit in software will cause an interrupt if enabled.

**IE2** bit 4 **External Interrupt 2 Flag.** This bit will be set when a rising edge is detected on INT2. This bit must be cleared manually by software. Setting this bit in software will cause an interrupt if enabled.

### Memory Page (MPAGE)

	7	6	5	4	3	2	1	0	Reset Value
SFR 92 <sub>H</sub>									00 <sub>H</sub>

**MPAGE** bits 7-0 The 8051 uses Port 2 for the upper 8 bits of the external data memory access by MOVX A, @ R<sub>i</sub> and MOVX @ R<sub>i</sub>, A instructions. The MSC1210 uses register MPAGE instead of Port 2. To access external data memory using the MOVX A, @ R<sub>i</sub> and MOVX @ R<sub>i</sub>, A instructions, the user should preload the upper byte of the address into MPAGE (versus preloading into P2 for the standard 8051).

### Configuration Address Register (CADDR)

	7	6	5	4	3	2	1	0	Reset Value
SFR 93 <sub>H</sub>									00 <sub>H</sub>

**CADDR** bits 7-0 **Configuration Address Register.** This register supplies the address for reading bytes in the 128 bytes of Flash Configuration Memory. WARNING: If this register is written to while executing from Flash Memory, the CADDR register will be incorrect.

## Configuration Data Register (CDATA)

SUNSTAR传感器与控制 <http://www.sensor-ic.com/> TEL:0755-83376549 FAX:0755-83376182 E-MAIL:szss20@163.com

	7	6	5	4	3	2	1	0	Reset Value
SFR 94 <sub>H</sub>									00 <sub>H</sub>

**CDATA Configuration Data Register.** This register will contain the data in the 128 bytes of Flash Configuration Memory bits 7-0 that is located at the last written address in the CADDR register. This is a read-only register.

## Memory Control (MCON)

	7	6	5	4	3	2	1	0	Reset Value
SFR 95 <sub>H</sub>	BPSEL	Reserved	Reserved	—	—	—	—	RAMMAP	00 <sub>H</sub>

### BPSEL Breakpoint Address Selection

bit 7 Write: Select one of two Breakpoint registers: 0 or 1.  
Read: Provides the Breakpoint register that created the last interrupt: 0 or 1.

### RAMMAP Memory Map 1kB data RAM.

bit 0 0: Address is: 0000<sub>H</sub>-03FF<sub>H</sub> (default) (Data Memory)  
1: In Program Mode, Address is: 7C00<sub>H</sub>-7FFF<sub>H</sub>  
In User Mode, Address is 8400<sub>H</sub>-87FF<sub>H</sub> (Data or Program Memory)

RAMMAP	USER	PROG
0	0000 <sub>H</sub> -3FFF <sub>H</sub>	0000 <sub>H</sub> -3FFF <sub>H</sub>
1	8400 <sub>H</sub> -87FF <sub>H</sub>	7C00 <sub>H</sub> -7FFF <sub>H</sub>

## Serial Port 0 Control (SCON0)

	7	6	5	4	3	2	1	0	Reset Value
SFR 98 <sub>H</sub>	SM0_0	SM1_0	SM2_0	REN_0	TB8_0	RB8_0	TI_0	RI_0	00 <sub>H</sub>

**SM0-2** Serial Port 0 Mode. These bits control the mode of serial Port 0. Modes 1, 2, and 3 have 1 start and 1 stop bit in addition to the 8 or 9 data bits.

MODE	SM0	SM1	SM2	FUNCTION	LENGTH	PERIOD
0	0	0	0	Synchronous	8 bits	12 p <sub>CLK</sub> <sup>(1)</sup>
0	0	0	1	Synchronous	8 bits	4 p <sub>CLK</sub> <sup>(1)</sup>
1	0	1	x	Asynchronous	10 bits	Timer 1 or 2 Baud Rate Equation
2	1	0	0	Asynchronous	11 bits	64 p <sub>CLK</sub> <sup>(1)</sup> (SMOD = 0) 32 p <sub>CLK</sub> <sup>(1)</sup> (SMOD = 1)
2	1	0	1	Asynchronous with Multiprocessor Communication	11 bits	64 p <sub>CLK</sub> <sup>(1)</sup> (SMOD = 0) 32 p <sub>CLK</sub> <sup>(1)</sup> (SMOD = 1)
3	1	1	0	Asynchronous	11 bits	Timer 1 or 2 Baud Rate Equation
3	1	1	1	Asynchronous with Multiprocessor Communication	11 bits	Timer 1 or 2 Baud Rate Equation

NOTE: (1) p<sub>CLK</sub> will be equal to t<sub>CLK</sub>, except that p<sub>CLK</sub> will stop for IDLE.

**REN\_0** **Receive Enable.** This bit enables/disables the serial Port 0 received shift register.

bit 4 0: Serial Port 0 reception disabled.  
1: Serial Port 0 received enabled (modes 1, 2, and 3). Initiate synchronous reception (mode 0).

**TB8\_0** **9<sup>th</sup> Transmission Bit State.** This bit defines the state of the 9<sup>th</sup> transmission bit in serial Port 0 modes 2 and 3.

bit 3

**RB8\_0** **9<sup>th</sup> Received Bit State.** This bit identifies the state of the 9<sup>th</sup> reception bit of received data in serial Port 0 modes 2 and 3. In serial port mode 1, when SM2\_0 = 0, RB8\_0 is the state of the stop bit. RB8\_0 is not used in mode 0.

bit 2

**TI\_0** **Transmitter Interrupt Flag.** This bit indicates that data in the serial Port 0 buffer has been completely shifted out. In serial port mode 0, TI\_0 is set at the end of the 8<sup>th</sup> data bit. In all other modes, this bit is set at the end of the last data bit. This bit must be manually cleared by software.

bit 1

**RI\_0** **Receiver Interrupt Flag.** This bit indicates that a byte of data has been received in the serial Port 0 buffer. In serial port mode 0, RI\_0 is set at the end of the 8<sup>th</sup> bit. In serial port mode 1, RI\_0 is set after the last sample of the incoming stop bit subject to the state of SM2\_0. In modes 2 and 3, RI\_0 is set after the last sample of RB8\_0. This bit must be manually cleared by software.

bit 0

## Serial Data Buffer 0 (SBUF0)

SUNSTAR 传感与控制 <http://www.sensor-ic.com/> TEL:0755-83376549 FAX:0755-83376182 E-MAIL:szss20@163.com

	7	6	5	4	3	2	1	0	Reset Value
SFR 99 <sub>H</sub>									00 <sub>H</sub>

**SBUF0**      **Serial Data Buffer 0.** Data for Serial Port 0 is read from or written to this location. The serial transmit and receive buffers are separate registers, but both are addressed at this location.  
bits 7-0

## SPI Control (SPICON). Any Change resets the SPI interface, counters, and pointers.

	7	6	5	4	3	2	1	0	Reset Value
SFR 9A <sub>H</sub>	SCLK2	SCLK1	SCLK0	FIFO	ORDER	MSTR	CPHA	CPOL	00 <sub>H</sub>

**SCLK**      **SCLK Selection.** Selection of  $t_{CLK}$  divider for generation of SCLK in Master mode.  
bits 7-5

SCLK2	SCLK1	SCLK0	SCLK PERIOD
0	0	0	$t_{CLK}/2$
0	0	1	$t_{CLK}/4$
0	1	0	$t_{CLK}/8$
0	1	1	$t_{CLK}/16$
1	0	0	$t_{CLK}/32$
1	0	1	$t_{CLK}/64$
1	1	0	$t_{CLK}/128$
1	1	1	$t_{CLK}/256$

**FIFO**      **Enable FIFO in on-chip indirect memory.**  
bit 4  
0: Both transmit and receive are double buffers  
1: Circular FIFO used for transmit and receive bytes

**ORDER**      **Set Bit Order for Transmit and Receive.**  
bit 3  
0: Most Significant Bits First  
1: Least Significant Bits First

**MSTR**      **SPI Master Mode.**  
bit 2  
0: Slave Mode  
1: Master Mode

**CPHA**      **Serial Clock Phase Control.**  
bit 1  
0: Valid data starting from half SCLK period before the first edge of SCLK  
1: Valid data starting from the first edge of SCLK

**CPOL**      **Serial Clock Polarity.**  
bit 0  
0: SCLK idle at logic LOW  
1: SCLK idle at logic HIGH

## SPI Data Register (SPIDATA)

	7	6	5	4	3	2	1	0	Reset Value
SFR 9B <sub>H</sub>									00 <sub>H</sub>

**SPIDATA**      **SPI Data Register.** Data for SPI is read from or written to this location. The SPI transmit and receive buffers are separate registers, but both are addressed at this location.  
bits 7-0

## SPI Receive Control Register (SPIRCON)

SUNSTAR传感器控制 http://www.sensor-ic.com/ TEL:0755-83376549 FAX:0755-83376182 E-MAIL:szss20@163.com

	7	6	5	4	3	2	1	0	Reset Value
SFR 9C <sub>H</sub>	RXCNT7 RXFLUSH	RXCNT6	RXCNT5	RXCNT4	RXCNT3	RXCNT2 RXIRQ2	RXCNT1 RXIRQ1	RXCNT0 RXIRQ0	00 <sub>H</sub>

**RxCNT** **Receive Counter.** Read only bits which read the number of bytes in the receive buffer (0 to 128).  
bits 7-0

**RXFLUSH** **Flush Receive FIFO.** Write only.  
bit 7  
0: No Action  
1: SPI Receive Buffer Set to Empty

**RxIRQ** **Read IRQ Level.** Write only.  
bits 2-0

000	Generate IRQ when Receive Count = 1 or more.
001	Generate IRQ when Receive Count = 2 or more.
010	Generate IRQ when Receive Count = 4 or more.
011	Generate IRQ when Receive Count = 8 or more.
100	Generate IRQ when Receive Count = 16 or more.
101	Generate IRQ when Receive Count = 32 or more.
110	Generate IRQ when Receive Count = 64 or more.
111	Generate IRQ when Receive Count = 128 or more.

## SPI Transmit Control Register (SPITCON)

	7	6	5	4	3	2	1	0	Reset Value
SFR 9D <sub>H</sub>	TXCNT7 TXFLUSH	TXCNT6	TXCNT5 CLK_EN	TXCNT4 DRV_DLY	TXCNT3 DRV_EN	TXCNT2 TXIRQ2	TXCNT1 TXIRQ1	TXCNT0 TXIRQ0	00 <sub>H</sub>

**TxCNT** **Transmit Counter.** Read only bits which read the number of bytes in the transmit buffer (0 to 128).  
bits 7-0

**TXFLUSH** **Flush Transmit FIFO.** This bit is write only. When set, the SPI transmit pointer is set equal to the FIFO Output pointer. This bit is 0 for a read operation.  
bit 7

**CLK\_EN** **SCLK Driver Enable.**  
bit 5  
0: Disable SCLK Driver (Master Mode)  
1: Enable SCLK Driver (Master Mode)

**DRV\_DLY** **Drive Delay.**  
bit 4

**DRV\_EN** **Drive Enable.**  
bit 3

DRV_DLY	DRV_EN	MOSI or MISO OUTPUT CONTROL
0	0	Tristate Immediately
0	1	Drive Immediately
1	0	Tristate After the Current Byte Transfer
1	1	Drive After the Current Byte Transfer

**TxIRQ** **Transmit IRQ Level.** Write only bits.  
bits 2-0

000	Generate IRQ when Transmit count = 1 or less.
001	Generate IRQ when Transmit count = 2 or less.
010	Generate IRQ when Transmit count = 4 or less.
011	Generate IRQ when Transmit count = 8 or less.
100	Generate IRQ when Transmit count = 16 or less.
101	Generate IRQ when Transmit count = 32 or less.
110	Generate IRQ when Transmit count = 64 or less.
111	Generate IRQ when Transmit count = 128 or less.

## SPI Buffer Start Address (SPISTART)

SUNSTAR 传感与控制 <http://www.sensor-ic.com/> TEL:0755-83376549 FAX:0755-83376182 E-MAIL:szss20@163.com

	7	6	5	4	3	2	1	0	Reset Value
SFR 9E <sub>H</sub>	1								80 <sub>H</sub>

**SPISTART** **SPI FIFO Start Address.** Write only. This specifies the start address of the SPI data buffer. This is a circular FIFO that is located in the 128 bytes of indirect RAM. The FIFO starts at this address and ends at the address specified in SPIEND. Must be less than SPIEND. Writing clears SPI transmit and receive counters.  
bits 6-0

**SPI TP** **SPI Transmit Pointer.** Read Only. This is the FIFO address for SPI transmissions. This is where the next byte will be written into the SPI FIFO buffer. This pointer increments after each write to the SPI Data register unless that would make it equal to the SPI Receive pointer.  
bits 6-0

## SPI Buffer End Address (SPIEND)

	7	6	5	4	3	2	1	0	Reset Value
SFR 9F <sub>H</sub>	1								80 <sub>H</sub>

**SPIEND** **SPI FIFO End Address.** Write only. This specifies the end address of the SPI data FIFO. This is a circular buffer that is located in the 128 bytes of indirect RAM. The buffer starts at SPISTRT and ends at this address.  
bits 6-0

**SPI RP** **SPI Receive Pointer.** Read Only. This is the FIFO address for SPI received bytes. This is the location of the next byte to be read from the SPI FIFO. This increments with each read from the SPI Data register until the RxCNT is zero.  
bits 6-0

## Port 2 (P2)

	7	6	5	4	3	2	1	0	Reset Value
SFR A0 <sub>H</sub>									FF <sub>H</sub>

**P2** **Port 2.** This port functions as an address bus during external memory access, and as a general-purpose I/O port. During external memory cycles, this port will contain the MSB of the address. Whether Port 2 is used as general-purpose I/O or for external memory access is determined by the Flash Configuration Register (HCR1.0).  
bits 7-0

## PWM Control (PWMCON)

	7	6	5	4	3	2	1	0	Reset Value
SFR A1 <sub>H</sub>	—	—	PPOL	PWMSEL	SPDSEL	TPCNTL.2	TPCNTL.1	TPCNTL.0	00 <sub>H</sub>

**PPOL** **Period Polarity.** Specifies the starting level of the PWM pulse.  
**bit 5**  
0: ON Period. PWM Duty register programs the ON period.  
1: OFF Period. PWM Duty register programs the OFF period.

**PWMSEL** **PWM Register Select.** Select which 16-bit register is accessed by PWMLOW/PWMHIGH.  
**bit 4**  
0: Period  
1: Duty

**SPDSEL** **Speed Select.**  
**bit 3**  
0: 1MHz (ONEUSEC Clock)  
1: SYSCLK

**TPCNTL** **Tone Generator/Pulse Width Modulation Control.**

bits 2-0	TPCNTL.2	TPCNTL.1	TPCNTL.0	MODE
	0	0	0	Disable (default)
	0	0	1	PWM
	0	1	1	TONE—Square
	1	1	1	TONE—Staircase

## Tone Low (TONELOW) /PWM Low (PWMLOW)

	7	6	5	4	3	2	1	0	Reset Value
SFR A2 <sub>H</sub>	TDIV7 PWM7	TDIV6 PWM6	TDIV5 PWM5	TDIV4 PWM4	TDIV3 PWM3	TDIV2 PWM2	TDIV1 PWM1	TDIV0 PWM0	00 <sub>H</sub>

**TDIVxx** **Tone Divisor.** The low order bits that define the half-time period. For staircase mode the output is high impedance for the last 1/4 of this period.  
bits 7-0

**PWMLOW** **Pulse Width Modulator Low Bits.** These 8 bits are the least significant 8 bits of the PWM register.  
bits 7-0

## Tone High (TONEHI)/PWM High (PWMHI)

SUNSTAR自动化控制 <http://www.sensor-ic.com/> TEL:0755-83376549 FAX:0755-83376182 E-MAIL:szss20@163.com

	7	6	5	4	3	2	1	0	Reset Value
SFR A3 <sub>H</sub>	TDIV15 PWM15	TDIV14 PWM14	TDIV13 PWM13	TDIV12 PWM12	TDIV11 PWM11	TDIV10 PWM10	TDIV09 PWM9	TDIV08 PWM8	00 <sub>H</sub>

**TDIVxx** **Tone Divisor.** The high order bits that define the half time period. For staircase mode the output is high bits 4-0 impedance for the last 1/4 of this period.

**PWMHI** **Pulse Width Modulator High Bits.** These 8 bits are the high order bits of the PWM register. bits 7-0

## Pending Auxiliary Interrupt (PAI)

	7	6	5	4	3	2	1	0	Reset Value
SFR A5 <sub>H</sub>	0	0	0	0	PAI3	PAI2	PAI1	PAI0	00 <sub>H</sub>

**PPI** **Pending Auxiliary Interrupt Register.** The results of this register can be used as an index to vector to the appropriate interrupt routine. All of these interrupts vector through address 0033<sub>H</sub>. bits 3-0

PAI3	PAI2	PAI1	PAI0	AUXILIARY INTERRUPT STATUS
0	0	0	0	No Pending Auxiliary IRQ
0	0	0	1	Digital Low Voltage IRQ Pending
0	0	1	0	Analog Low Voltage IRQ Pending
0	0	1	1	SPI Receive IRQ Pending
0	1	0	0	SPI Transmit IRQ Pending
0	1	0	1	One Millisecond System Timer IRQ Pending
0	1	1	0	Analog to Digital Conversion IRQ Pending
0	1	1	1	Accumulator IRQ Pending
1	0	0	0	One Second System Timer IRQ Pending

## Auxiliary Interrupt Enable (AIE)

	7	6	5	4	3	2	1	0	Reset Value
SFR A6 <sub>H</sub>	ESEC	ESUM	EADC	EMSEC	ESPI3	ESPI2	EALV	EDLVB	00 <sub>H</sub>

Interrupts are enabled by EICON.4 (SFR D8<sub>H</sub>). The other interrupts are controlled by the IE and EIE registers.

**ESEC** **Seconds Timer Interrupt Bit (lowest priority auxiliary interrupt).**

bit 7 Write: Set mask bit for this interrupt 0 = masked, 1 = enabled.  
Read: Current value of **Seconds Timer Interrupt** before masking.

**ESUM** **Summation Interrupt Bit.**

bit 6 Write: Set mask bit for this interrupt 0 = masked, 1 = enabled.  
Read: Current value of **Summation Interrupt** before masking.

**EADC** **ADC Interrupt Bit.**

bit 5 Write: Set mask bit for this interrupt 0 = masked, 1 = enabled.  
Read: Current value of **ADC Interrupt** before masking.

**EMSEC** **Millisecond System Timer Interrupt Bit.**

bit 4 Write: Set mask bit for this interrupt 0 = masked, 1 = enabled.  
Read: Current value of **Millisecond System Timer Interrupt** before masking.

**ESPI3** **SPI Transmit Interrupt Bit.**

bit 3 Write: Set mask bit for this interrupt 0 = masked, 1 = enabled.  
Read: Current value of **SPI Transmit Interrupt** before masking.

**ESPI2** **SPI Receive Interrupt Bit.**

bit 2 Write: Set mask bit for this interrupt 0 = masked, 1 = enabled.  
Read: Current value of **SPI Receive Interrupt** before masking.

**EALV** **Analog Low Voltage Interrupt Bit.**

bit 1 Write: Set mask bit for this interrupt 0 = masked, 1 = enabled.  
Read: Current value of **Analog Low Voltage Interrupt** before masking.

**EDLVB** **Digital Low Voltage or Breakpoint Interrupt Bit (highest priority auxiliary interrupt).**

bit 0 Write: Set mask bit for this interrupt 0 = masked, 1 = enabled.  
Read: Current value of **Digital Low Voltage or Breakpoint Interrupt** before masking.

## Auxiliary Interrupt Status Register (AISTAT)

SUNSTAR自动化控制 <http://www.sensor-ic.com/> TEL:0755-83376549 FAX:0755-83376182 E-MAIL:szss20@163.com

	7	6	5	4	3	2	1	0	Reset Value
SFR A7 <sub>H</sub>	SEC	SUM	ADC	MSEC	SPIT	SPIR	ALVD	DLVD	00 <sub>H</sub>

### SEC Second System Timer Interrupt Status Flag (lowest priority AI).

bit 7  
0: SEC interrupt inactive or masked.  
1: SEC Interrupt active.

### SUM Summation Register Interrupt Status Flag.

bit 6  
0: SUM interrupt inactive or masked (if active, it is set inactive by reading the lowest byte of the Summation register).  
1: SUM interrupt active.

### ADC ADC Interrupt Status Flag.

bit 5  
0: ADC interrupt inactive or masked (If active, it is set inactive by reading the lowest byte of the Data Output Register).  
1: ADC interrupt active (If active no new data will be written to the Data Output Register).

### MSEC Millisecond System Timer Interrupt Status Flag.

bit 4  
0: MSEC interrupt inactive or masked.  
1: MSEC interrupt active.

### SPIT SPI Transmit Interrupt Status Flag.

bit 3  
0: SPI transmit interrupt inactive or masked.  
1: SPI transmit interrupt active.

### SPIR SPI Receive Interrupt Status Flag.

bit 2  
0: SPI receive interrupt inactive or masked.  
1: SPI receive interrupt active.

### ALVD Analog Low Voltage Detect Interrupt Status Flag.

bit 1  
0: ALVD interrupt inactive or masked.  
1: ALVD interrupt active.

### DLVD Digital Low Voltage Detect or Breakpoint Interrupt Status Flag (highest priority AI).

bit 0  
0: DLVD interrupt inactive or masked.  
1: DLVD interrupt active.

## Interrupt Enable (IE)

	7	6	5	4	3	2	1	0	Reset Value
SFR A8 <sub>H</sub>	EA	ES1	ET2	ES0	ET1	EX1	ET0	EX0	00 <sub>H</sub>

**EA Global Interrupt Enable.** This bit controls the global masking of all interrupts except those in AIE (SFR A6<sub>H</sub>).  
bit 7  
0: Disable interrupt sources. This bit overrides individual interrupt mask settings for this register.  
1: Enable all individual interrupt masks. Individual interrupts in this register will occur if enabled.

**ES1 Enable Serial Port 1 Interrupt.** This bit controls the masking of the serial Port 1 interrupt.  
bit 6  
0: Disable all serial Port 1 interrupts.  
1: Enable interrupt requests generated by the RI\_1 (SCON1.0, SFR C0<sub>H</sub>) or TI\_1 (SCON1.1, SFR C0<sub>H</sub>) flags.

**ET2 Enable Timer 2 Interrupt.** This bit controls the masking of the Timer 2 interrupt.  
bit 5  
0: Disable all Timer 2 interrupts.  
1: Enable interrupt requests generated by the TF2 flag (T2CON.7, SFR C8<sub>H</sub>).

**ES0 Enable Serial port 0 interrupt.** This bit controls the masking of the serial Port 0 interrupt.  
bit 4  
0: Disable all serial Port 0 interrupts.  
1: Enable interrupt requests generated by the RI\_0 (SCON0.0, SFR 98<sub>H</sub>) or TI\_0 (SCON0.1, SFR 98<sub>H</sub>) flags.

- ET1** **Enable Timer 1 Interrupt.** This bit controls the masking of the Timer 1 interrupt.  
bit 3  
0: Disable all Timer 1 interrupt.  
1: Enable interrupt requests generated by the TF1 flag (TCON.7, SFR 88<sub>H</sub>).
- EX1** **Enable External Interrupt 1.** This bit controls the masking of external interrupt 1.  
bit 2  
0: Disable external interrupt 1.  
1: Enable interrupt requests generated by the  $\overline{\text{INT1}}$  pin.
- ET0** **Enable Timer 0 Interrupt.** This bit controls the masking of the Timer 0 interrupt.  
bit 1  
0: Disable all Timer 0 interrupts.  
1: Enable interrupt requests generated by the TF0 flag (TCON.5, SFR 88<sub>H</sub>).
- EX0** **Enable External Interrupt 0.** This bit controls the masking of external interrupt 0.  
bit 0  
0: Disable external interrupt 0.  
1: Enable interrupt requests generated by the  $\overline{\text{INT0}}$  pin.

### Breakpoint Control (BPCON)

	7	6	5	4	3	2	1	0	Reset Value
SFR A9 <sub>H</sub>	BP	0	0	0	0	0	PMSEL	EBP	00 <sub>H</sub>

Writing to register sets the breakpoint condition specified by MCON, BPL, and BPH.

- BP** **Breakpoint Interrupt.** This bit indicates that a break condition has been recognized by a hardware breakpoint register(s).  
bit 7  
Read: Status of Breakpoint Interrupt. Will indicate a breakpoint match for any of the breakpoint registers.  
Write: 0: No effect.  
1: Clear Breakpoint 1 for breakpoint register selected by MCON (SFR 95<sub>H</sub>).
- PMSEL** **Program Memory Select.** Write this bit to select memory for address breakpoints of register selected in MCON (SFR 95<sub>H</sub>).  
bit 1  
0: Break on address in data memory.  
1: Break on address in program memory.
- EBP** **Enable Breakpoint.** This bit enables this breakpoint register. Address of breakpoint register selected by MCON (SFR 95<sub>H</sub>).  
bit 0  
0: Breakpoint disabled.  
1: Breakpoint enabled.

### Breakpoint Low (BPL) Address for BP Register Selected in MCON (95<sub>H</sub>)

	7	6	5	4	3	2	1	0	Reset Value
SFR AA <sub>H</sub>	BPL.7	BPL.6	BPL.5	BPL.4	BPL.3	BPL.2	BPL.1	BPL.0	00 <sub>H</sub>

**BPL.7-0** **Breakpoint Low Address.** The low 8 bits of the 16 bit breakpoint address.  
bits 7-0

### Breakpoint High Address (BPH) Address for BP Register Selected in MCON (95<sub>H</sub>)

	7	6	5	4	3	2	1	0	Reset Value
SFR AB <sub>H</sub>	BPH.7	BPH.6	BPH.5	BPH.4	BPH.3	BPH.2	BPH.1	BPH.0	00 <sub>H</sub>

**BPH.7-0** **Breakpoint High Address.** The high 8 bits of the 16 bit breakpoint address.  
bits 7-0

## Port 0 Data Direction Low Register (P0DDRL)

SUNSTAR 传感与控制 <http://www.sensor-ic.com/> TEL: 0755-83376549 FAX: 0755-83376182 E-MAIL: szss20@163.com

	7	6	5	4	3	2	1	0	Reset Value
SFR AC <sub>H</sub>	P03H	P03L	P02H	P02L	P01H	P01L	P00H	P00L	00 <sub>H</sub>

### P0.3 Port 0 bit 3 control.

bits 7-6

P03H	P03L	
0	0	Standard 8051(Pull-Up)
0	1	CMOS Output
1	0	Open Drain Output
1	1	Input

### P0.2 Port 0 bit 2 control.

bits 5-4

P02H	P02L	
0	0	Standard 8051(Pull-Up)
0	1	CMOS Output
1	0	Open Drain Output
1	1	Input

### P0.1 Port 0 bit 1 control.

bits 3-2

P01H	P01L	
0	0	Standard 8051(Pull-Up)
0	1	CMOS Output
1	0	Open Drain Output
1	1	Input

### P0.0 Port 0 bit 0 control.

bits 1-0

P00H	P00L	
0	0	Standard 8051(Pull-Up)
0	1	CMOS Output
1	0	Open Drain Output
1	1	Input

NOTE: Port 0 also controlled by  $\bar{E}A$  and Memory Access Control HCR1.1.

## Port 0 Data Direction High Register (P0DDRH)

	7	6	5	4	3	2	1	0	Reset Value
SFR AD <sub>H</sub>	P07H	P07L	P06H	P06L	P05H	P05L	P04H	P04L	00 <sub>H</sub>

### P0.7 Port 0 bit 7 control.

bits 7-6

P07H	P07L	
0	0	Standard 8051(Pull-Up)
0	1	CMOS Output
1	0	Open Drain Output
1	1	Input

### P0.6 Port 0 bit 6 control.

bits 5-4

P06H	P06L	
0	0	Standard 8051(Pull-Up)
0	1	CMOS Output
1	0	Open Drain Output
1	1	Input

### P0.5 Port 0 bit 5 control.

bits 3-2

P05H	P05L	
0	0	Standard 8051(Pull-Up)
0	1	CMOS Output
1	0	Open Drain Output
1	1	Input

### P0.4 Port 0 bit 4 control.

bits 1-0

P04H	P04L	
0	0	Standard 8051(Pull-Up)
0	1	CMOS Output
1	0	Open Drain Output
1	1	Input

NOTE: Port 0 also controlled by  $\bar{E}A$  and Memory Access Control HCR1.1.

## Port 1 Data Direction Low Register (P1DDRL)

SUNSTAR 传感与控制 <http://www.sensor-ic.com/> TEL:0755-83376549 FAX:0755-83376182 E-MAIL:szss20@163.com

	7	6	5	4	3	2	1	0	Reset Value
SFR AE <sub>H</sub>	P13H	P13L	P12H	P12L	P11H	P11L	P10H	P10L	00 <sub>H</sub>

### P1.3 Port 1 bit 3 control.

bits 7-6

P13H	P13L	
0	0	Standard 8051
0	1	CMOS Output
1	0	Open Drain Output
1	1	Input

### P1.2 Port 1 bit 2 control.

bits 5-4

P12H	P12L	
0	0	Standard 8051
0	1	CMOS Output
1	0	Open Drain Output
1	1	Input

### P1.1 Port 1 bit 1 control.

bits 3-2

P11H	P11L	
0	0	Standard 8051
0	1	CMOS Output
1	0	Open Drain Output
1	1	Input

### P1.0 Port 1 bit 0 control.

bits 1-0

P10H	P10L	
0	0	Standard 8051
0	1	CMOS Output
1	0	Open Drain Output
1	1	Input

## Port 1 Data Direction High Register (P1DDRH)

	7	6	5	4	3	2	1	0	Reset Value
SFR AF <sub>H</sub>	P17H	P17L	P16H	P16L	P15H	P15L	P14H	P14L	00 <sub>H</sub>

### P1.7 Port 1 bit 7 control.

bits 7-6

P17H	P17L	
0	0	Standard 8051
0	1	CMOS Output
1	0	Open Drain Output
1	1	Input

### P1.6 Port 1 bit 6 control.

bits 5-4

P16H	P16L	
0	0	Standard 8051
0	1	CMOS Output
1	0	Open Drain Output
1	1	Input

### P1.5 Port 1 bit 5 control.

bits 3-2

P15H	P15L	
0	0	Standard 8051
0	1	CMOS Output
1	0	Open Drain Output
1	1	Input

### P1.4 Port 1 bit 4 control.

bits 1-0

P14H	P14L	
0	0	Standard 8051
0	1	CMOS Output
1	0	Open Drain Output
1	1	Input

### Port 3 (P3)

	7	6	5	4	3	2	1	0	Reset Value
SFR B0 <sub>H</sub>	P3.7 $\overline{RD}$	P3.6 $\overline{WR}$	P3.5 T1	P3.4 T0	P3.3 $\overline{INT1}$	P3.2 $\overline{INT0}$	P3.1 TXD0	P3.0 RXD0	FF <sub>H</sub>

**P3.7-0** **General-Purpose I/O Port 3.** This register functions as a general-purpose I/O port. In addition, all the pins have bits 7-0 an alternative function listed below. Each of the functions is controlled by several other SFRs. The associated Port 3 latch bit must contain a logic '1' before the pin can be used in its alternate function capacity.

**$\overline{RD}$**  **External Data Memory Read Strobe.** This pin provides an active low read strobe to an external memory device. bit 7 If Port 0 or Port 2 is selected for external memory in the HCR1 register, this function will be enabled even if a 1 is not written to this latch bit. When external memory is selected, the settings of P3DRRH are ignored.

**$\overline{WR}$**  **External Data Memory Write Strobe.** This pin provides an active low write strobe to an external memory device. bit 6 If Port 0 or Port 2 is selected for external memory in the HCR1 register, this function will be enabled even if a 1 is not written to this latch bit. When external memory is selected, the settings of P3DRRH are ignored.

**T1** **Timer/Counter 1 External Input.** A 1 to 0 transition on this pin will increment Timer 1. bit 5

**T0** **Timer/Counter 0 External Input.** A 1 to 0 transition on this pin will increment Timer 0. bit 4

**$\overline{INT1}$**  **External Interrupt 1.** A falling edge/low level on this pin will cause an external interrupt 1 if enabled. bit 3

**$\overline{INT0}$**  **External Interrupt 0.** A falling edge/low level on this pin will cause an external interrupt 0 if enabled. bit 2

**TXD0** **Serial Port 0 Transmit.** This pin transmits the serial Port 0 data in serial port modes 1, 2, 3, and emits the bit 1 synchronizing clock in serial port mode 0.

**RXD0** **Serial Port 0 Receive.** This pin receives the serial Port 0 data in serial port modes 1, 2, 3, and is a bidirectional bit 0 data transfer pin in serial port mode 0.

### Port 2 Data Direction Low Register (P2DDRL)

	7	6	5	4	3	2	1	0	Reset Value
SFR B1 <sub>H</sub>	P23H	P23L	P22H	P22L	P21H	P21L	P20H	P20L	00 <sub>H</sub>

**P2.3** **Port 2 bit 3 control.**  
bits 7-6

P23H	P23L	
0	0	Standard 8051
0	1	CMOS Output
1	0	Open Drain Output
1	1	Input

**P2.2** **Port 2 bit 2 control.**  
bits 5-4

P22H	P22L	
0	0	Standard 8051
0	1	CMOS Output
1	0	Open Drain Output
1	1	Input

**P2.1** **Port 2 bit 1 control.**  
bits 3-2

P21H	P21L	
0	0	Standard 8051
0	1	CMOS Output
1	0	Open Drain Output
1	1	Input

**P2.0** **Port 2 bit 0 control.**  
bits 1-0

P20H	P20L	
0	0	Standard 8051
0	1	CMOS Output
1	0	Open Drain Output
1	1	Input

NOTE: Port 2 also controlled by  $\overline{EA}$  and Memory Access Control HCR1.1.

## Port 2 Data Direction High Register (P2DDRH)

SUNSTAR 传感与控制 <http://www.sensor-ic.com/> TEL:0755-83376549 FAX:0755-83376182 E-MAIL:szss20@163.com

	7	6	5	4	3	2	1	0	Reset Value
SFR B2 <sub>H</sub>	P27H	P27L	P26H	P26L	P25H	P25L	P24H	P24L	00 <sub>H</sub>

### P2.7 Port 2 bit 7 control.

bits 7-6

P27H	P27L	
0	0	Standard 8051
0	1	CMOS Output
1	0	Open Drain Output
1	1	Input

### P2.6 Port 2 bit 6 control.

bits 5-4

P26H	P26L	
0	0	Standard 8051
0	1	CMOS Output
1	0	Open Drain Output
1	1	Input

### P2.5 Port 2 bit 5 control.

bits 3-2

P25H	P25L	
0	0	Standard 8051
0	1	CMOS Output
1	0	Open Drain Output
1	1	Input

### P2.4 Port 2 bit 4 control.

bits 1-0

P24H	P24L	
0	0	Standard 8051
0	1	CMOS Output
1	0	Open Drain Output
1	1	Input

NOTE: Port 2 also controlled by  $\overline{EA}$  and Memory Access Control HCR1.1.

## Port 3 Data Direction Low Register (P3DDRL)

	7	6	5	4	3	2	1	0	Reset Value
SFR B3 <sub>H</sub>	P33H	P33L	P32H	P32L	P31H	P31L	P30H	P30L	00 <sub>H</sub>

### P3.3 Port 3 bit 3 control.

bits 7-6

P33H	P33L	
0	0	Standard 8051
0	1	CMOS Output
1	0	Open Drain Output
1	1	Input

### P3.2 Port 3 bit 2 control.

bits 5-4

P32H	P32L	
0	0	Standard 8051
0	1	CMOS Output
1	0	Open Drain Output
1	1	Input

### P3.1 Port 3 bit 1 control.

bits 3-2

P31H	P31L	
0	0	Standard 8051
0	1	CMOS Output
1	0	Open Drain Output
1	1	Input

### P3.0 Port 3 bit 0 control.

bits 1-0

P30H	P30L	
0	0	Standard 8051
0	1	CMOS Output
1	0	Open Drain Output
1	1	Input

## Port 3 Data Direction High Register (P3DDRH)

SUNSTAR自动化控制 <http://www.sensor-ic.com/> TEL: 0755-83376549 FAX: 0755-83376182 E-MAIL: szss20@163.com

	7	6	5	4	3	2	1	0	Reset Value
SFR B4 <sub>H</sub>	P37H	P37L	P36H	P36L	P35H	P35L	P34H	P34L	00 <sub>H</sub>

### P3.7 Port 3 bit 7 control.

bits 7-6

P37H	P37L	
0	0	Standard 8051
0	1	CMOS Output
1	0	Open Drain Output
1	1	Input

NOTE: Port 3.7 also controlled by  $\bar{E}A$  and Memory Access Control HCR1.1.

### P3.6 Port 3 bit 6 control.

bits 5-4

P36H	P36L	
0	0	Standard 8051
0	1	CMOS Output
1	0	Open Drain Output
1	1	Input

NOTE: Port 3.6 also controlled by  $\bar{E}A$  and Memory Access Control HCR1.1.

### P3.5 Port 3 bit 5 control.

bits 3-2

P35H	P35L	
0	0	Standard 8051
0	1	CMOS Output
1	0	Open Drain Output
1	1	Input

### P3.4 Port 3 bit 4 control.

bits 1-0

P34H	P34L	
0	0	Standard 8051
0	1	CMOS Output
1	0	Open Drain Output
1	1	Input

## Interrupt Priority (IP)

	7	6	5	4	3	2	1	0	Reset Value
SFR B8 <sub>H</sub>	1	PS1	PT2	PS0	PT1	PX1	PT0	PX0	80 <sub>H</sub>

**PS1 Serial Port 1 Interrupt.** This bit controls the priority of the serial Port 1 interrupt.

bit 6  
0 = Serial Port 1 priority is determined by the natural priority order.  
1 = Serial Port 1 is a high priority interrupt.

**PT2 Timer 2 Interrupt.** This bit controls the priority of the Timer 2 interrupt.

bit 5  
0 = Timer 2 priority is determined by the natural priority order.  
1 = Timer 2 priority is a high priority interrupt.

**PS0 Serial Port 0 Interrupt.** This bit controls the priority of the serial Port 0 interrupt.

bit 4  
0 = Serial Port 0 priority is determined by the natural priority order.  
1 = Serial Port 0 is a high priority interrupt.

**PT1 Timer 1 Interrupt.** This bit controls the priority of the Timer 1 interrupt.

bit 3  
0 = Timer 1 priority is determined by the natural priority order.  
1 = Timer 1 priority is a high priority interrupt.

**PX1 External Interrupt 1.** This bit controls the priority of external interrupt 1.

bit 2  
0 = External interrupt 1 priority is determined by the natural priority order.  
1 = External interrupt 1 is a high priority interrupt.

**PT0 Timer 0 Interrupt.** This bit controls the priority of the Timer 0 interrupt.

bit 1  
0 = Timer 0 priority is determined by the natural priority order.  
1 = Timer 0 priority is a high priority interrupt.

**PX0 External Interrupt 0.** This bit controls the priority of external interrupt 0.

bit 0  
0 = External interrupt 0 priority is determined by the natural priority order.  
1 = External interrupt 0 is a high priority interrupt.

## Serial Port 1 Control (SCON1)

SUNSTAR传感与控制 <http://www.sensor-ic.com/> TEL:0755-83376549 FAX:0755-83376182 E-MAIL:szss20@163.com

	7	6	5	4	3	2	1	0	Reset Value
SFR C0 <sub>H</sub>	SM0_1	SM1_1	SM2_1	REN_1	TB8_1	RB8_1	TI_1	RI_1	00 <sub>H</sub>

**SM0-2** Serial Port 1 Mode. These bits control the mode of serial Port 1. Modes 1, 2, and 3 have 1 start and 1 stop bit in addition to the 8 or 9 data bits.

MODE	SM0	SM1	SM2	FUNCTION	LENGTH	PERIOD
0	0	0	0	Synchronous	8 bits	12 p <sub>CLK</sub> <sup>(1)</sup>
0	0	0	1	Synchronous	8 bits	4 p <sub>CLK</sub> <sup>(1)</sup>
1	0	1	x	Asynchronous	10 bits	Timer 1 or 2 Baud Rate Equation
2	1	0	0	Asynchronous	11 bits	64 p <sub>CLK</sub> <sup>(1)</sup> (SMOD = 0) 32 p <sub>CLK</sub> <sup>(1)</sup> (SMOD = 1)
2	1	0	1	Asynchronous with Multiprocessor Communication	11 bits	64 p <sub>CLK</sub> <sup>(1)</sup> (SMOD = 0) 32 p <sub>CLK</sub> <sup>(1)</sup> (SMOD = 1)
3	1	1	0	Asynchronous	11 bits	Timer 1 or 2 Baud Rate Equation
3	1	1	1	Asynchronous with Multiprocessor Communication	11 bits	Timer 1 or 2 Baud Rate Equation

NOTE: (1) p<sub>CLK</sub> will be equal to t<sub>CLK</sub>, except that p<sub>CLK</sub> will stop for IDLE.

**REN\_1** **Receive Enable.** This bit enables/disables the serial Port 1 received shift register.  
bit 4 0 = Serial Port 1 reception disabled.

1 = Serial Port 1 received enabled (modes 1, 2, and 3). Initiate synchronous reception (mode 0).

**TB8\_1** **9<sup>th</sup> Transmission Bit State.** This bit defines the state of the 9<sup>th</sup> transmission bit in serial Port 1 modes 2 and 3.  
bit 3

**RB8\_1** **9<sup>th</sup> Received Bit State.** This bit identifies the state of the 9<sup>th</sup> reception bit of received data in serial Port 1 modes 2 and 3. In serial port mode 1, when SM2\_1 = 0, RB8\_1 is the state of the stop bit. RB8\_1 is not used in mode 0.  
bit 2

**TI\_1** **Transmitter Interrupt Flag.** This bit indicates that data in the serial Port 1 buffer has been completely shifted out. In serial port mode 0, TI\_1 is set at the end of the 8<sup>th</sup> data bit. In all other modes, this bit is set at the end of the last data bit. This bit must be cleared by software to transmit the next byte.  
bit 1

**RI\_1** **Receiver Interrupt Flag.** This bit indicates that a byte of data has been received in the serial Port 1 buffer. In serial port mode 0, RI\_1 is set at the end of the 8<sup>th</sup> bit. In serial port mode 1, RI\_1 is set after the last sample of the incoming stop bit subject to the state of SM2\_1. In modes 2 and 3, RI\_1 is set after the last sample of RB8\_1. This bit must be cleared by software to receive the next byte.  
bit 0

## Serial Data Buffer 1 (SBUF1)

	7	6	5	4	3	2	1	0	Reset Value
SFR C1 <sub>H</sub>									00 <sub>H</sub>

**SBUF1.7-0** **Serial Data Buffer 1.** Data for serial Port 1 is read from or written to this location. The serial transmit and receive buffers are separate registers, but both are addressed at this location.

## Enable Wake Up (EWU) Waking Up from IDLE Mode

	7	6	5	4	3	2	1	0	Reset Value
SFR C6 <sub>H</sub>	—	—	—	—	—	EWUWDT	EWUEX1	EWUEX0	00 <sub>H</sub>

**EWUWDT** **Enable Wake Up External 1.** Wake using external interrupt source 1.  
bit 2 0 = don't wake up on external interrupt source 1.  
1 = wake up on external interrupt source 1.

**EWUEX1** **Enable Wake Up External 0.** Wake using external interrupt source 0.  
bit 1 0 = don't wake up on external interrupt source 0.  
1 = wake up on external interrupt source 0.

**EWUEX0** **Enable Wake Up Watchdog Timer.** Wake using watchdog timer interrupt.  
bit 0 0 = don't wake up on watchdog timer interrupt.  
1 = wake up on watchdog timer interrupt.

## Timer 2 Control (T2CON)

SUNSTAR传感与控制 <http://www.sensor-ic.com/> TEL:0755-83376549 FAX:0755-83376182 E-MAIL:szss20@163.com

	7	6	5	4	3	2	1	0	Reset Value
SFR C8 <sub>H</sub>	TF2	EXF2	RCLK	TCLK	EXEN2	TR2	C/T2	CP/RL2	00 <sub>H</sub>

- TF2** bit 7 **Timer 2 Overflow Flag.** This flag will be set when Timer 2 overflows from FFFF<sub>H</sub>. It must be cleared by software. TF2 will only be set if RCLK and TCLK are both cleared to 0. Writing a 1 to TF2 forces a Timer 2 interrupt if enabled.
- EXF2** bit 6 **Timer 2 External Flag.** A negative transition on the T2EX pin (P1.1) will cause this flag to be set based on the EXEN2 (T2CON.3) bit. If set by a negative transition, this flag must be cleared to 0 by software. Setting this bit in software will force a timer interrupt if enabled.
- RCLK** bit 5 **Receive Clock Flag.** This bit determines the serial Port 0 timebase when receiving data in serial modes 1 or 3.  
0 = Timer 1 overflow is used to determine receiver baud rate for serial Port 0.  
1 = Timer 2 overflow is used to determine receiver baud rate for serial Port 0.  
Setting this bit will force Timer 2 into baud rate generation mode. The timer will operate from a divide by 2 of the external clock.
- TCLK** bit 4 **Transmit Clock Flag.** This bit determines the serial Port 0 timerbase when transmitting data in serial modes 1 or 3.  
0 = Timer 1 overflow is used to determine transmitter baud rate for serial Port 0.  
1 = Timer 2 overflow is used to determine transmitter baud rate for serial Port 0.  
Setting this bit will force Timer 2 into baud rate generation mode. The timer will operate from a divide by 2 of the external clock.
- EXEN2** bit 3 **Timer 2 External Enable.** This bit enables the capture/reload function on the T2EX pin if Timer 2 is not generating baud rates for the serial port.  
0 = Timer 2 will ignore all external events at T2EX.  
1 = Timer 2 will capture or reload a value if a negative transition is detected on the T2EX pin.
- TR2** bit 2 **Timer 1 Run Control.** This bit enables/disables the operation of Timer 2. Halting this timer will preserve the current count in TH2, TL2.  
0 = Timer 2 is halted.  
1 = Timer 2 is enabled.
- C/T2** bit 1 **Counter/Timer Select.** This bit determines whether Timer 2 will function as a timer or counter. Independent of this bit, Timer 2 runs at 2 clocks per tick when used in baud rate generator mode.  
0 = Timer 2 functions as a timer. The speed of Timer 2 is determined by the T2M bit (CKCON.5).  
1 = Timer 2 will count negative transitions on the T2 pin (P1.0).
- CP/RL2** bit 0 **Capture/Reload Select.** This bit determines whether the capture or reload function will be used for Timer 2. If either RCLK or TCLK is set, this bit will not function and the timer will function in an auto-reload mode following each overflow.  
0 = Auto-reloads will occur when Timer 2 overflows or a falling edge is detected on T2EX if EXEN2 = 1.  
1 = Timer 2 captures will occur when a falling edge is detected on T2EX if EXEN2 = 1.

## Timer 2 Capture LSB (RCAP2L)

	7	6	5	4	3	2	1	0	Reset Value
SFR CA <sub>H</sub>									00 <sub>H</sub>

- RCAP2L** bits 7-0 **Timer 2 Capture LSB.** This register is used to capture the TL2 value when Timer 2 is configured in capture mode. RCAP2L is also used as the LSB of a 16-bit reload value when Timer 2 is configured in auto-reload mode.

## Timer 2 Capture MSB (RCAP2H)

SUNSTAR 传感与控制 <http://www.sensor-ic.com/> TEL:0755-83376549 FAX:0755-83376182 E-MAIL:szss20@163.com

	7	6	5	4	3	2	1	0	Reset Value
SFR CB <sub>H</sub>									00 <sub>H</sub>

**RCAP2H** **Timer 2 Capture MSB.** This register is used to capture the TH2 value when Timer 2 is configured in capture mode. RCAP2H is also used as the MSB of a 16-bit reload value when Timer 2 is configured in auto-reload mode.  
bits 7-0

## Timer 2 LSB (TL2)

	7	6	5	4	3	2	1	0	Reset Value
SFR CC <sub>H</sub>									00 <sub>H</sub>

**TL2** **Timer 2 LSB.** This register contains the least significant byte of Timer 2.  
bits 7-0

## Timer 2 MSB (TH2)

	7	6	5	4	3	2	1	0	Reset Value
SFR CD <sub>H</sub>									00 <sub>H</sub>

**TH2** **Timer 2 MSB.** This register contains the most significant byte of Timer 2.  
bits 7-0

## Program Status Word (PSW)

	7	6	5	4	3	2	1	0	Reset Value
SFR D0 <sub>H</sub>	CY	AC	F0	RS1	RS0	OV	F1	P	00 <sub>H</sub>

**CY** **Carry Flag.** This bit is set when the last arithmetic operation resulted in a carry (during addition) or a borrow (during subtraction). Otherwise it is cleared to 0 by all arithmetic operations.  
bit 7

**AC** **Auxiliary Carry Flag.** This bit is set to 1 if the last arithmetic operation resulted in a carry into (during addition), or a borrow (during subtraction) from the high order nibble. Otherwise it is cleared to 0 by all arithmetic operations.  
bit 6

**F0** **User Flag 0.** This is a bit-addressable, general-purpose flag for software control.  
bit 5

**RS1, RS0** **Register Bank Select 1-0.** These bits select which register bank is addressed during register accesses.  
bits 4-3

RS1	RS0	REGISTER BANK	ADDRESS
0	0	0	00 <sub>H</sub> -07 <sub>H</sub>
0	1	1	08 <sub>H</sub> -0F <sub>H</sub>
1	0	2	10 <sub>H</sub> -17 <sub>H</sub>
1	1	3	18 <sub>H</sub> -1F <sub>H</sub>

**OV** **Overflow Flag.** This bit is set to 1 if the last arithmetic operation resulted in a carry (addition), borrow (subtraction), or overflow (multiply or divide). Otherwise it is cleared to 0 by all arithmetic operations.  
bit 2

**F1** **User Flag 1.** This is a bit-addressable, general-purpose flag for software control.  
bit 1

**P** **Parity Flag.** This bit is set to 1 if the modulo-2 sum of the 8 bits of the accumulator is 1 (odd parity); and cleared to 0 on even parity.  
bit 0

## ADC Offset Calibration Register Low Byte (OCL)

	7	6	5	4	3	2	1	0	Reset Value
SFR D1 <sub>H</sub>									00 <sub>H</sub>

**OCL** **ADC Offset Calibration Register Low Byte.** This is the low byte of the 24 bit word that contains the ADC offset calibration. A value which is written to this location will set the ADC offset calibration value.  
bits 7-0

### ADC Offset Calibration Register Middle Byte (OCM)

SUNSTAR传感与控制 <http://www.sensor-ic.com/> TEL: 0755-83376549 FAX: 0755-83376182 E-MAIL: szss20@163.com

	7	6	5	4	3	2	1	0	Reset Value
SFR D2 <sub>H</sub>									00 <sub>H</sub>

**OCRM** **ADC Offset Calibration Register Middle Byte.** This is the middle byte of the 24-bit word that contains the ADC offset calibration. A value which is written to this location will set the ADC offset calibration value.

### ADC Offset Calibration Register High Byte (OCH)

	7	6	5	4	3	2	1	0	Reset Value
SFR D3 <sub>H</sub>									00 <sub>H</sub>

**OCRH** **ADC Offset Calibration Register High Byte.** This is the high byte of the 24-bit word that contains the ADC offset calibration. A value which is written to this location will set the ADC offset calibration value.

### ADC Gain Calibration Register Low Byte (GCL)

	7	6	5	4	3	2	1	0	Reset Value
SFR D4 <sub>H</sub>									5A <sub>H</sub>

**GCRL** **ADC Gain Calibration Register Low Byte.** This is the low byte of the 24-bit word that contains the ADC gain calibration. A value which is written to this location will set the ADC gain calibration value.

### ADC Gain Calibration Register Middle Byte (GCM)

	7	6	5	4	3	2	1	0	Reset Value
SFR D5 <sub>H</sub>									EC <sub>H</sub>

**GCRM** **ADC Gain Calibration Register Middle Byte.** This is the middle byte of the 24-bit word that contains the ADC gain calibration. A value which is written to this location will set the ADC gain calibration value.

### ADC Gain Calibration Register High Byte (GCH)

	7	6	5	4	3	2	1	0	Reset Value
SFR D6 <sub>H</sub>									5F <sub>H</sub>

**GCRH** **ADC Gain Calibration Register High Byte.** This is the high byte of the 24-bit word that contains the ADC gain calibration. A value which is written to this location will set the ADC gain calibration value.

### ADC Multiplexer Register (ADMUX)

	7	6	5	4	3	2	1	0	Reset Value
SFR D7 <sub>H</sub>	INP3	INP2	INP1	INP0	INN3	INN2	INN1	INN0	01 <sub>H</sub>

**INP3-0** **Input Multiplexer Positive Channel.** This selects the positive signal input.  
bits 7-4

INP3	INP2	INP1	INP0	POSITIVE INPUT
0	0	0	0	AIN0 (default)
0	0	0	1	AIN1
0	0	1	0	AIN2
0	0	1	1	AIN3
0	1	0	0	AIN4
0	1	0	1	AIN5
0	1	1	0	AIN6
0	1	1	1	AIN7
1	0	0	0	AINCOM
1	1	1	1	Temperature Sensor (Requires ADMUX = FF <sub>H</sub> )

INN3	INN2	INN1	INN0	NEGATIVE INPUT
0	0	0	0	AIN0
0	0	0	1	AIN1 (default)
0	0	1	0	AIN2
0	0	1	1	AIN3
0	1	0	0	AIN4
0	1	0	1	AIN5
0	1	1	0	AIN6
0	1	1	1	AIN7
1	0	0	0	AINCOM
1	1	1	1	Temperature Sensor (Requires ADMUX = FF <sub>H</sub> )

**Enable Interrupt Control (EICON)**

	7	6	5	4	3	2	1	0	Reset Value
SFR D8 <sub>H</sub>	SMOD1	1	EAI	AI	WDTI	0	0	0	40 <sub>H</sub>

**SMOD1** **Serial Port 1 Mode.** When this bit is set the serial baud rate for Port 1 will be doubled.  
bit 7  
0 = Standard baud rate for Port 1 (default).  
1 = Double baud rate for Port 1.

**EAI** **Enable Auxiliary Interrupt.** The Auxiliary Interrupt accesses nine different interrupts which are masked and identified by SFR registers PAI (SFR A5<sub>H</sub>), AIE (SFR A6<sub>H</sub>), and AISTAT (SFR A7<sub>H</sub>).  
bit 5  
0 = Auxiliary Interrupt disabled (default).  
1 = Auxiliary Interrupt enabled.

**AI** **Auxiliary Interrupt Flag.** AI must be cleared by software before exiting the interrupt service routine, after the source of the interrupt is cleared. Otherwise, the interrupt occurs again. Setting AI in software generates an Auxiliary Interrupt, if enabled.  
bit 4  
0 = No Auxiliary Interrupt detected (default).  
1 = Auxiliary Interrupt detected.

**WDTI** **Watchdog Timer Interrupt Flag.** WDTI must be cleared by software before exiting the interrupt service routine. Otherwise, the interrupt occurs again. Setting WDTI in software generates a watchdog time interrupt, if enabled. The Watchdog timer can generate an interrupt or reset. The interrupt is available only if the reset action is disabled in HCR0.  
bit 3  
0 = No Watchdog Timer Interrupt Detected (default).  
1 = Watchdog Timer Interrupt Detected.

**ADC Results Register Low Byte (ADRESL)**

	7	6	5	4	3	2	1	0	Reset Value
SFR D9 <sub>H</sub>									00 <sub>H</sub>

**ADRESL** **The ADC Results Low Byte.** This is the low byte of the 24 bit word that contains the ADC Converter Results. Reading from this register resets the ADC interrupt.  
bits 7-0

**ADC Results Register Middle Byte (ADRESM)**

	7	6	5	4	3	2	1	0	Reset Value
SFR DA <sub>H</sub>									00 <sub>H</sub>

**ADRESM** **The ADC Results Middle Byte.** This is the middle byte of the 24 bit word that contains the ADC Converter Results.  
bits 7-0

**ADC Results Register High Byte (ADRESH)**

	7	6	5	4	3	2	1	0	Reset Value
SFR DB <sub>H</sub>									00 <sub>H</sub>

**ADRESH** **The ADC Results High Byte.** This is the high byte of the 24 bit word that contains the ADC Converter Results.  
bits 7-0

## ADC Control Register 0 (ADCON0)

SUNSTAR传感器控制 <http://www.sensor-ic.com/> TEL:0755-83376549 FAX:0755-83376182 E-MAIL:szss20@163.com

	7	6	5	4	3	2	1	0	Reset Value
SFR DC <sub>H</sub>	—	BOD	EVREF	VREFH	EBUF	PGA2	PGA1	PGA0	30 <sub>H</sub>

**BOD** **Burnout Detect.** When enabled this connects a positive current source to the positive channel and a negative current source to the negative channel. If the channel is open circuit then the ADC results will be full-scale.

bit 6

0 = Burnout Current Sources Off (default).

1 = Burnout Current Sources On.

**EVREF**

bit 5

**Enable Internal Voltage Reference.** If the internal voltage reference is not used, it should be turned off to save power and reduce noise.

0 = Internal Voltage Reference Off.

1 = Internal Voltage Reference On (default).

**VREFH**

bit 4

**Voltage Reference High Select.** The internal voltage reference can be selected to be 2.5V or 1.25V.

0 = REF<sub>OUT</sub> is 1.25V.

1 = REF<sub>OUT</sub> is 2.5V (default).

**EBUF**

bit 3

**Enable Buffer.** Enable the input buffer to provide higher input impedance but limits the input voltage range and dissipates higher power.

0 = Buffer disabled (default).

1 = Buffer enabled.

**PGA2-0**

bits 2-0

**Programmable Gain Amplifier.** Sets the gain for the PGA from 1 to 128.

PGA2	PGA1	PGA0	GAIN
0	0	0	1 (default)
0	0	1	2
0	1	0	4
0	1	1	8
1	0	0	16
1	0	1	32
1	1	0	64
1	1	1	128

## ADC Control Register 1 (ADCON1)

	7	6	5	4	3	2	1	0	Reset Value
SFR DD <sub>H</sub>	—	POL	SM1	SM0	—	CAL2	CAL1	CAL0	x000 0000 <sub>B</sub>

**POL**

bit 6

**Polarity.** Polarity of the ADC results and Summation register.

0 = Bipolar.

1 = Unipolar. Resolution (LSB size) is 1/2 the resolution of Bipolar.

POL	ANALOG INPUT	DIGITAL OUTPUT
0	+FSR	0x7FFFFFFF
	ZERO	0x000000
	-FSR	0x800000
1	+FSR	0xFFFFFFFF
	ZERO	0x000000
	-FSR	0x000000

**SM1-0**

bits 5-4

**Settling Mode.** Selects the type of filter or auto select which defines the digital filter settling characteristics.

SM1	SM0	SETTLING MODE
0	0	Auto
0	1	Quick Convert
1	0	Sinc <sup>2</sup> Filter
1	1	Sinc <sup>3</sup> Filter

**CAL2-0**  
bits 2-0

**Calibration Mode Control Bits**

SUNSTAR传感与控制 <http://www.sensor-ic.com/> TEL:0755-83376549 FAX:0755-83376182 E-MAIL:szss20@163.com

CAL2	CAL1	CAL0	CALIBRATION MODE
0	0	0	No Calibration (default)
0	0	1	Self Calibration, Offset and Gain
0	1	0	Self Calibration, Offset Only
0	1	1	Self Calibration, Gain Only
1	0	0	System Calibration, Offset Only
1	0	1	System Calibration, Gain Only
1	1	0	Reserved
1	1	1	Reserved

Read Value—000<sub>B</sub>.

**ADC Control Register 2 (ADCON2)**

	7	6	5	4	3	2	1	0	Reset Value
SFR DE <sub>H</sub>	DR7	DR6	DR5	DR4	DR3	DR2	DR1	DR0	1B <sub>H</sub>

**DR7-0 Decimation Ratio LSB.**

bits 7-0

**ADC Control Register 3 (ADCON3)**

	7	6	5	4	3	2	1	0	Reset Value
SFR DF <sub>H</sub>	—	—	—	—	—	DR10	DR9	DR8	06 <sub>H</sub>

**DR10-8 Decimation Ratio Most Significant 3 Bits.** The output data rate = (ACLK + 1)/64/Decimation Ratio.

bits 2-0

**Accumulator (A or ACC)**

	7	6	5	4	3	2	1	0	Reset Value
SFR E0 <sub>H</sub>	ACC.7	ACC.6	ACC.5	ACC.4	ACC.3	ACC.2	ACC.1	ACC.0	00 <sub>H</sub>

**ACC.7-0 Accumulator.** This register serves as the accumulator for arithmetic and logic operations.

bits 7-0

**Summation/Shifter Control (SSCON)**

	7	6	5	4	3	2	1	0	Reset Value
SFR E1 <sub>H</sub>	SSCON1	SSCON0	SCNT2	SCNT1	SCNT0	SHF2	SHF1	SHF0	00 <sub>H</sub>

The Summation register is powered down when the ADC is powered down. If all zeroes are written to this register the 32-bit SUMR3-0 registers will be cleared. The Summation registers will do sign extend if Bipolar is selected in ADCON1.

**SSCON1-0 Summation/Shift Control.**

bits 7-6

SOURCE	SSCON1	SSCON0	MODE
CPU	0	0	Values written to the SUM registers are accumulated when the SUMR0 value is written.
ADC	0	1	Summation register Enabled. Source is ADC, summation count is working.
CPU	1	0	Shift Enabled. Summation register is shifted by SHF Count bits. It takes four system clocks to execute.
ADC	1	1	Accumulate and Shift Enable. Values are accumulated for SUM Count times and then shifted by SHF Count.

**SCNT2-0 Summation Count.** When the summation is complete an interrupt will be generated unless masked. Reading the SUMR0 register clears the interrupt.

bits 5-3

SCNT2	SCNT1	SCNT0	SUMMATION COUNT
0	0	0	2
0	0	1	4
0	1	0	8
0	1	1	16
1	0	0	32
1	0	1	64
1	1	0	128
1	1	1	256

**SHF2-0 Shift Count**  
bits 2-0

SHF2	SHF1	SHF0	SHIFT	DIVIDE
0	0	0	1	2
0	0	1	2	4
0	1	0	3	8
0	1	1	4	16
1	0	0	5	32
1	0	1	6	64
1	1	0	7	128
1	1	1	8	256

**Summation Register 0 (SUMR0)**

	7	6	5	4	3	2	1	0	Reset Value
SFR E2 <sub>H</sub>									00 <sub>H</sub>

**SUMR0 Summation Register 0.** This is the least significant byte of the 32-bit summation register or bits 0 to 7.  
bits 7-0 Write: will cause values in SUMR3-0 to be added to the summation register.  
Read: will clear the Summation Count Interrupt.

**Summation Register 1 (SUMR1)**

	7	6	5	4	3	2	1	0	Reset Value
SFR E3 <sub>H</sub>									00 <sub>H</sub>

**SUMR1 Summation Register 1.** This is the most significant byte of the lowest 16 bits of the summation register or bits 8-15.  
bits 7-0

**Summation Register 2 (SUMR2)**

	7	6	5	4	3	2	1	0	Reset Value
SFR E4 <sub>H</sub>									00 <sub>H</sub>

**SUMR2 Summation Register 2.** This is the most significant byte of the lowest 24 bits of the summation register or bits 16-23.  
bits 7-0

**Summation Register 3 (SUMR3)**

	7	6	5	4	3	2	1	0	Reset Value
SFR E5 <sub>H</sub>									00 <sub>H</sub>

**SUMR3 Summation Register 3.** This is the most significant byte of the 32-bit summation register or bits 24-31.  
bits 7-0

**Offset DAC Register (ODAC)**

	7	6	5	4	3	2	1	0	Reset Value
SFR E6 <sub>H</sub>									00 <sub>H</sub>

**ODAC Offset DAC Register.** This register will shift the input by up to half of the ADC input range. The least significant bit is equal to the input voltage range divided by 256. The input range will depend on the setting of the PGA. With  $V_{REF} = 2.5V$  in unipolar mode, for a gain of 1 the range is 5V. For a PGA of 128 the range is 40mV. The ODAC is a signed magnitude register with bit 7 providing the sign of the offset and bits 6-0 providing the magnitude.

## Low Voltage Detect Control (LVDCON)

SUNSTAR 传感与控制 <http://www.sensor-ic.com/> TEL:0755-83376549 FAX:0755-83376182 E-MAIL:szss20@163.com

	7	6	5	4	3	2	1	0	Reset Value
SFR E7 <sub>H</sub>	ALVDIS	ALVD2	ALVD1	ALVD0	DLVDIS	DLVD2	DLVD1	DLVD0	00 <sub>H</sub>

### ALVDIS Analog Low Voltage Detect Disable.

bit 7  
0 = Enable Detection of Low Analog Supply Voltage, if ABOD bit in HCR1 is set.  
1 = Disable Detection of Low Analog Supply Voltage.

### ALVD2-0 Analog Voltage Detection Level.

bits 6-4

ALVD2	ALVD1	ALVD0	VOLTAGE LEVEL
0	0	0	AV <sub>DD</sub> 2.7V (default)
0	0	1	AV <sub>DD</sub> 3.0V
0	1	0	AV <sub>DD</sub> 3.3V
0	1	1	AV <sub>DD</sub> 4.0V
1	0	0	AV <sub>DD</sub> 4.2V
1	0	1	AV <sub>DD</sub> 4.5V
1	1	0	AV <sub>DD</sub> 4.7V
1	1	1	External Voltage AIN7 Compared to 1.2V

### DLVDIS Digital Low Voltage Detect Disable.

bit 3  
0 = Enable Detection of Low Digital Supply Voltage, if DBOD bit in HCR1 is set.  
1 = Disable Detection of Low Digital Supply Voltage.

### DLVD2-0 Digital Voltage Detection Level.

bits 2-0

DLVD2	DLVD1	DLVD0	VOLTAGE LEVEL
0	0	0	DV <sub>DD</sub> 2.7V (default)
0	0	1	DV <sub>DD</sub> 3.0V
0	1	0	DV <sub>DD</sub> 3.3V
0	1	1	DV <sub>DD</sub> 4.0V
1	0	0	DV <sub>DD</sub> 4.2V
1	0	1	DV <sub>DD</sub> 4.5V
1	1	0	DV <sub>DD</sub> 4.7V
1	1	1	External Voltage AIN6 Compared to 1.2V

## Extended Interrupt Enable (EIE)

	7	6	5	4	3	2	1	0	Reset Value
SFR E8 <sub>H</sub>	1	1	1	EWDI	EX5	EX4	EX3	EX2	E0 <sub>H</sub>

**EWDI Enable Watchdog Interrupt.** This bit enables/disables the watchdog interrupt. The Watchdog timer is enabled by the WDTCON (SFR FF<sub>H</sub>) and PDCON (SFR F1<sub>H</sub>) registers.

bit 4  
0 = Disable the Watchdog Interrupt  
1 = Enable Interrupt Request Generated by the Watchdog Timer

**EX5 External Interrupt 5 Enable.** This bit enables/disables external interrupt 5.

bit 3  
0 = Disable External Interrupt 5  
1 = Enable External Interrupt 5

**EX4 External Interrupt 4 Enable.** This bit enables/disables external interrupt 4.

bit 2  
0 = Disable External Interrupt 4  
1 = Enable External Interrupt 4

**EX3 External Interrupt 3 Enable.** This bit enables/disables external interrupt 3.

bit 1  
0 = Disable External Interrupt 3  
1 = Enable External Interrupt 3

**EX2 External Interrupt 2 Enable.** This bit enables/disables external interrupt 2.

bit 0  
0 = Disable External Interrupt 2  
1 = Enable External Interrupt 2

## Hardware Product Code Register 0 (HWPC0)

SUNSTAR 传感与控制 <http://www.sensor-ic.com/> TEL:0755-83376549 FAX:0755-83376182 E-MAIL:szss20@163.com

	7	6	5	4	3	2	1	0	Reset Value
SFR E9 <sub>H</sub>	HWPC0.7	HWPC0.6	HWPC0.5	HWPC0.4	HWPC0.3	HWPC0.2	MEMORY SIZE		0000_00xx

**HWPC0.7-0 Hardware Product Code LSB.** Read only.  
bits 7-0

MEMORY SIZE		MODEL	FLASH MEMORY
0	0	MSC1210Y2	4kB
0	1	MSC1210Y3	8kB
1	0	MSC1210Y4	16kB
1	1	MSC1210Y5	32kB

## Hardware Product Code Register 1 (HWPC1)

	7	6	5	4	3	2	1	0	Reset Value
SFR EA <sub>H</sub>	HWPC1.7	HWPC1.6	HWPC1.5	HWPC1.4	HWPC1.3	HWPC1.2	HWPC1.1	HWPC1.0	00 <sub>H</sub>

**HWPC1.7-0 Hardware Product Code MSB.** Read only.  
bits 7-0

## Flash Memory Control (FMCON)

	7	6	5	4	3	2	1	0	Reset Value
SFR EE <sub>H</sub>	0	PGERA	0	FRCM	—	BUSY	1	0	02 <sub>H</sub>

**PGERA Page Erase.** Available in both user and program modes.  
bit 6  
0 = Disable Page Erase Mode  
1 = Enable Page Erase Mode

**FRCM Frequency Control Mode.** The bypass is only used for slow clocks to save power.  
bit 4  
0 = Bypass (default)  
1 = Use Delay Line. Saves power (Recommended).

**BUSY Write/Erase BUSY Signal.**  
bit 2  
0 = Idle or Available  
1 = Busy

## Flash Memory Timing Control Register (FTCON)

	7	6	5	4	3	2	1	0	Reset Value
SFR EF <sub>H</sub>	FER3	FER2	FER1	FER0	FWR3	FWR2	FWR1	FWR0	A5 <sub>H</sub>

Refer to Flash Timing Characteristics

**FER3-0 Set Erase.** Flash Erase Time = (1 + FER) • (MSEC + 1) • t<sub>CLK</sub>.  
bits 7-4

**FWR3-0 Set Write.** Flash Write Time = (1 + FWR) • (USEC + 1) • 5 • t<sub>CLK</sub>.  
bits 3-0

	7	6	5	4	3	2	1	0	Reset Value
SFR F0 <sub>H</sub>	B.7	B.6	B.5	B.4	B.3	B.2	B.1	B.0	00 <sub>H</sub>

**B.7-0 B Register.** This register serves as a second accumulator for certain arithmetic operations.  
bits 7-0

**Power-Down Control Register (PDCON)**

	7	6	5	4	3	2	1	0	Reset Value
SFR F1 <sub>H</sub>	0	0	0	PDPWM	PDAD	PDWDT	PDST	PDSPi	1F <sub>H</sub>

Turning peripheral modules off puts the MSC1210 in the lowest power mode.

**PDPWM Pulse Width Module Control.**

bit 4 0 = PWM On  
1 = PWM Power Down

**PDAD ADC Control.**

bit 3 0 = ADC On  
1 = ADC, V<sub>REF</sub>, Summation registers, and Analog Brownout are powered down. Analog current = 0.

**PDWDT Watchdog Timer Control.**

bit 2 0 = Watchdog Timer On  
1 = Watchdog Timer Power Down

**PDST System Timer Control.**

bit 1 0 = System Timer On  
1 = System Timer Power Down

**PDSPi SPI System Control.**

bit 0 0 = SPI System On  
1 = SPI System Power Down

**PSEN/ALE Select (PASEL)**

	7	6	5	4	3	2	1	0	Reset Value
SFR F2 <sub>H</sub>	0	0	PSEN2	PSEN1	PSEN0	0	ALE1	ALE0	00 <sub>H</sub>

**PSEN2-0 PSEN Mode Select.**

bits 5-3

PSEN2	PSEN1	PSEN0	
0	0	X	$\overline{\text{PSEN}}$
0	1	X	CLK
1	0	X	ADC MODCLK
1	1	0	LOW
1	1	1	HIGH

**ALE1-0 ALE Mode Select.**

bits 1-0

ALE1	ALE0	
0	X	ALE
1	0	LOW
1	1	HIGH

## Analog Clock (ACLK)

SUNSTAR传感与控制 <http://www.sensor-ic.com/> TEL:0755-83376549 FAX:0755-83376182 E-MAIL:szss20@163.com

	7	6	5	4	3	2	1	0	Reset Value
SFR F6 <sub>H</sub>	0	0	0	FREQ4	FREQ3	FREQ2	FREQ1	FREQ0	03 <sub>H</sub>

**FREQ4-0 Clock Frequency** – 1. This value + 1 divides the system clock to create the ADC clock.

bits 4-0  $ADC\ Clock = System\ CLK / (FREQ + 1)$ ;  $f_{MOD} = [System\ CLK / (FREQ + 1)] / 64$ .

## System Reset Register (SRST)

	7	6	5	4	3	2	1	0	Reset Value
SFR F7 <sub>H</sub>	0	0	0	0	0	0	0	RSTREQ	00 <sub>H</sub>

**RSTREQ Reset Request.** Setting this bit to 1 and then 0 will generate a system reset.

bit 0

## Extended Interrupt Priority (EIP)

	7	6	5	4	3	2	1	0	Reset Value
SFR F8 <sub>H</sub>	1	1	1	PWDI	PX5	PX4	PX3	PX2	E0 <sub>H</sub>

**PWDI Watchdog Interrupt Priority.** This bit controls the priority of the watchdog interrupt.

bit 4 0 = The watchdog interrupt is low priority.

1 = The watchdog interrupt is high priority.

**PX5 External Interrupt 5 Priority.** This bit controls the priority of external interrupt 5.

bit 3 0 = External interrupt 5 is low priority.

1 = External interrupt 5 is high priority.

**PX4 External Interrupt 4 Priority.** This bit controls the priority of external interrupt 4.

bit 2 0 = External interrupt 4 is low priority.

1 = External interrupt 4 is high priority.

**PX3 External Interrupt 3 Priority.** This bit controls the priority of external interrupt 3.

bit 2 0 = External interrupt 3 is low priority.

1 = External interrupt 3 is high priority.

**PX2 External Interrupt 2 Priority.** This bit controls the priority of external interrupt 2.

bit 0 0 = External interrupt 2 is low priority.

1 = External interrupt 2 is high priority.

## Seconds Timer Interrupt (SECINT)

	7	6	5	4	3	2	1	0	Reset Value
SFR F9 <sub>H</sub>	WRT	SECINT6	SECINT5	SECINT4	SECINT3	SECINT2	SECINT1	SECINT0	7F <sub>H</sub>

This system clock is divided by the value of the 16-bit register MSEC. Then that 1ms timer tick is divided by the register HMSEC which provides the 100ms signal used by this seconds timer. Therefore, this seconds timer can generate an interrupt which occurs from 100ms to 12.8 seconds. Reading this register will clear the Seconds Interrupt. This Interrupt can be monitored in the AIE register.

**WRT Write Control.** Determines whether to write the value immediately or wait until the current count is finished.

bit 7 Read = 0.

0 = Delay Write Operation. The SEC value is loaded when the current count expires.

1 = Write Immediately. The counter is loaded once the CPU completes the write operation.

**SECINT6-0 Seconds Count.** Normal operation would use 100ms as the clock interval.

bits 6-0  $Seconds\ Interrupt = (1 + SEC) \cdot (HMSEC + 1) \cdot (MSEC + 1) \cdot t_{CLK}$ .

## Milliseconds Interrupt (MSINT)

SUNSTAR 传感与控制 <http://www.sensor-ic.com/> TEL:0755-83376549 FAX:0755-83376182 E-MAIL:szss20@163.com

	7	6	5	4	3	2	1	0	Reset Value
SFR FA <sub>H</sub>	WRT	MSINT6	MSINT5	MSINT4	MSINT3	MSINT2	MSINT1	MSINT0	7F <sub>H</sub>

The clock used for this timer is the 1ms clock which results from dividing the system clock by the values in registers FC<sub>H</sub> and FD<sub>H</sub>. Reading this register will clear the interrupt.

**WRT** **Write Control.** Determines whether to write the value immediately or wait until the current count is finished. Read = 0.  
 bit 7 0 = Delay Write Operation. The MSINT value is loaded when the current count expires.  
 1 = Write Immediately. The MSINT counter is loaded once the CPU completes the write operation.

**MSINT6-0** **Seconds Count.** Normal operation would use 1ms as the clock interval.  
 bits 6-0 MS Interrupt Interval = (1 + MSINT) • (MSEC + 1) • t<sub>CLK</sub>

## One Microsecond Register (USEC)

	7	6	5	4	3	2	1	0	Reset Value
SFR FB <sub>H</sub>	0	0	0	FREQ4	FREQ3	FREQ2	FREQ1	FREQ0	03 <sub>H</sub>

**FREQ4-0** **Clock Frequency – 1.** This value + 1 divides the system clock to create a 1μs Clock.  
 bits 4-0 USEC = CLK/(FREQ + 1). This clock is used to set Flash write time. See FTCON (SFR EF<sub>H</sub>).

## One Millisecond Low Register (MSECL)

	7	6	5	4	3	2	1	0	Reset Value
SFR FC <sub>H</sub>	MSECL7	MSECL6	MSECL5	MSECL4	MSECL3	MSECL2	MSECL1	MSECL0	9F <sub>H</sub>

**MSECL7-0** **One Millisecond Low.** This value in combination with the next register is used to create a 1ms Clock.  
 bits 7-0 1ms Clock = (MSECH • 256 + MSECL + 1) • t<sub>CLK</sub>. This clock is used to set Flash erase time. See FTCON (SFR EF<sub>H</sub>).

## One Millisecond High Register (MSECH)

	7	6	5	4	3	2	1	0	Reset Value
SFR FD <sub>H</sub>	MSECH7	MSECH6	MSECH5	MSECH4	MSECH3	MSECH2	MSECH1	MSECH0	0F <sub>H</sub>

**MSECH7-0** **One Millisecond High.** This value in combination with the previous register is used to create a 1ms clock.  
 bits 7-0 1ms = (MSECH • 256 + MSECL + 1) • t<sub>CLK</sub>.

## One Hundred Millisecond Register (HMSEC)

	7	6	5	4	3	2	1	0	Reset Value
SFR FE <sub>H</sub>	HMSEC7	HMSEC6	HMSEC5	HMSEC4	HMSEC3	HMSEC2	HMSEC1	HMSEC0	63 <sub>H</sub>

**HMSEC7-0** **One Hundred Millisecond.** This clock divides the 1ms clock to create a 100ms clock.  
 bits 7-0 100ms = (MSECH • 256 + MSECL + 1) • (HMSEC + 1) • t<sub>CLK</sub>.

## Watchdog Timer Register (WDTCON)

	7	6	5	4	3	2	1	0	Reset Value
SFR FF <sub>H</sub>	EWDT	DWDT	RWDT	WDCNT4	WDCNT3	WDCNT2	WDCNT1	WDCNT0	00 <sub>H</sub>

**EWDT** **Enable Watchdog.**  
 bit 7 Read: WDEN current value.  
 Write 1/Write 0 sequence sets the Watchdog Enable Counting bit.

**DWDT** **Disable Watchdog.**  
 bit 6 Read: WDDIS current value.  
 Write 1/Write 0 sequence clears the Watchdog Enable Counting bit.

**RWDT** **Reset Watchdog.**  
 bit 5 Read: WDRST current value.  
 Write 1/Write 0 sequence restarts the Watchdog Counter.

**WDCNT4-0** **Watchdog Count.**  
 bits 4-0 Watchdog expires in (WDCNT + 1) • HMSEC to (WDCNT + 2) • HMSEC, if the sequence is not asserted. There is an uncertainty of 1 count.

PAG (S-PQFP-G64)

PLASTIC QUAD FLATPACK

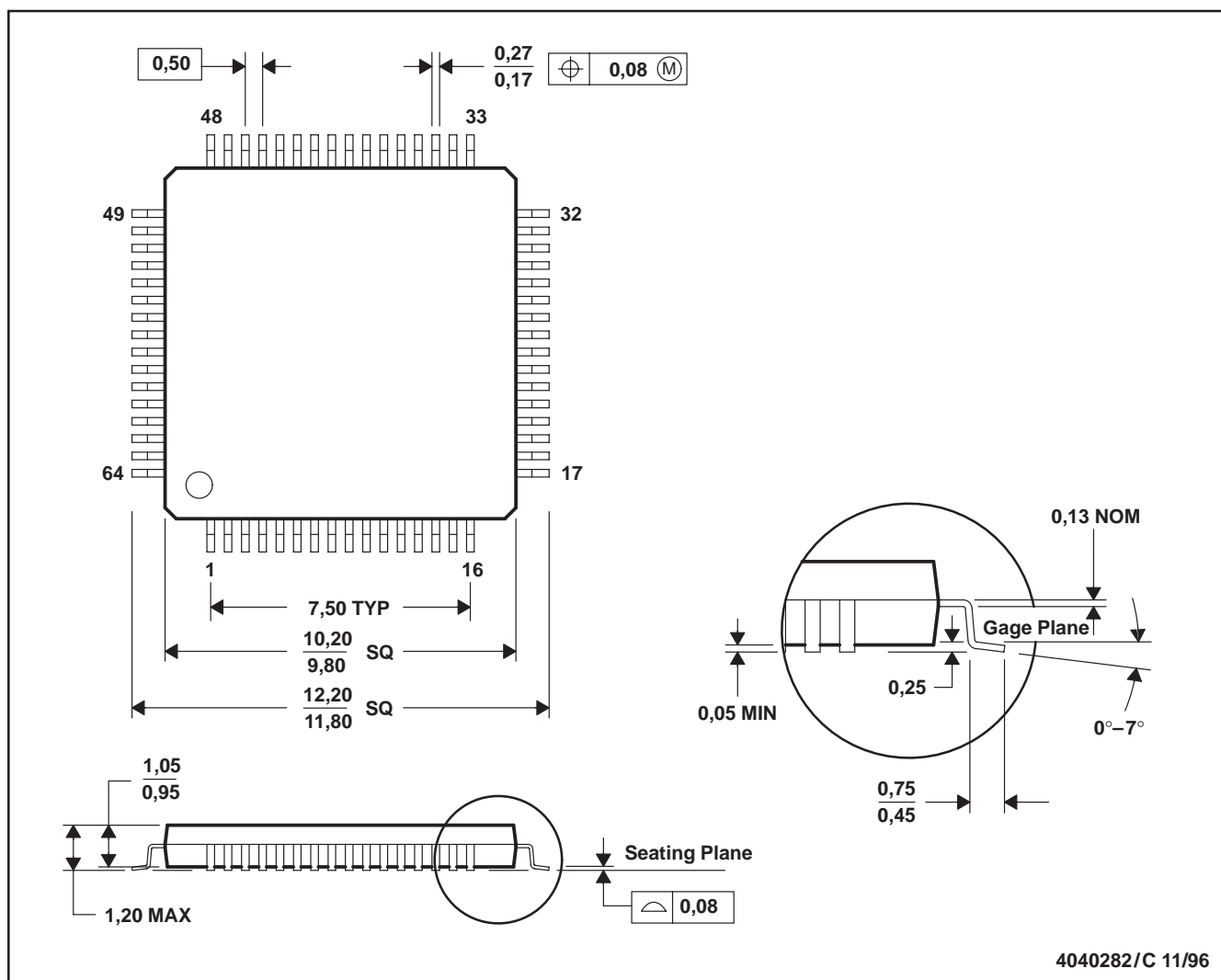

- NOTES: A. All linear dimensions are in millimeters.  
 B. This drawing is subject to change without notice.  
 C. Falls within JEDEC MS-026

## IMPORTANT NOTICE

Texas Instruments Incorporated and its subsidiaries (TI) reserve the right to make corrections, modifications, enhancements, improvements, and other changes to its products and services at any time and to discontinue any product or service without notice. Customers should obtain the latest relevant information before placing orders and should verify that such information is current and complete. All products are sold subject to TI's terms and conditions of sale supplied at the time of order acknowledgment.

TI warrants performance of its hardware products to the specifications applicable at the time of sale in accordance with TI's standard warranty. Testing and other quality control techniques are used to the extent TI deems necessary to support this warranty. Except where mandated by government requirements, testing of all parameters of each product is not necessarily performed.

TI assumes no liability for applications assistance or customer product design. Customers are responsible for their products and applications using TI components. To minimize the risks associated with customer products and applications, customers should provide adequate design and operating safeguards.

TI does not warrant or represent that any license, either express or implied, is granted under any TI patent right, copyright, mask work right, or other TI intellectual property right relating to any combination, machine, or process in which TI products or services are used. Information published by TI regarding third-party products or services does not constitute a license from TI to use such products or services or a warranty or endorsement thereof. Use of such information may require a license from a third party under the patents or other intellectual property of the third party, or a license from TI under the patents or other intellectual property of TI.

Reproduction of information in TI data books or data sheets is permissible only if reproduction is without alteration and is accompanied by all associated warranties, conditions, limitations, and notices. Reproduction of this information with alteration is an unfair and deceptive business practice. TI is not responsible or liable for such altered documentation.

Resale of TI products or services with statements different from or beyond the parameters stated by TI for that product or service voids all express and any implied warranties for the associated TI product or service and is an unfair and deceptive business practice. TI is not responsible or liable for any such statements.

### Mailing Address:

Texas Instruments  
Post Office Box 655303  
Dallas, Texas 75265

Copyright © 2002, Texas Instruments Incorporated

SUNSTAR商斯达实业集团是集研发、生产、工程、销售、代理经销、技术咨询、信息服务等为一体的高科技企业，是专业高科技电子产品生产厂家，是具有10多年历史的专业电子元器件供应商，是中国最早和最大的仓储式连锁规模经营大型综合电子零部件代理分销商之一，是一家专业代理和分销世界各大品牌IC芯片和电子元器件的连锁经营综合性国际公司。在香港、北京、深圳、上海、西安、成都等全国主要电子市场设有直属分公司和产品展示展销窗口门市部专卖店及代理分销商，已在全国范围内建成强大统一的供货和代理分销网络。我们专业代理经销、开发生产电子元器件、集成电路、传感器、微波光电元器件、工控机/DOC/DOM电子盘、专用电路、单片机开发、MCU/DSP/ARM/FPGA软件硬件、二极管、三极管、模块等，是您可靠的一站式现货配套供应商、方案提供商、部件功能模块开发配套商。专业以现代信息产业（计算机、通讯及传感器）三大支柱之一的传感器为主营业务，专业经营各类传感器的代理、销售生产、网络信息、科技图书资料及配套产品设计、工程开发。我们的专业网站——中国传感器科技信息网（全球传感器数据库）[www.SENSOR-IC.COM](http://www.SENSOR-IC.COM) 服务于全球高科技生产商及贸易商，为企业科技产品开发提供技术交流平台。欢迎各厂商互通有无、交换信息、交换链接、发布寻求代理信息。欢迎国外高科技传感器、变送器、执行器、自动控制产品厂商介绍产品到中国，共同开拓市场。本网站是关于各种传感器-变送器-仪器仪表及工业自动化大型专业网站，深入到工业控制、系统工程计 测量、自动化、安防报警、消费电子等众多领域，把最新的传感器-变送器-仪器仪表买卖信息，最新技术供求，最新采购商，行业动态，发展方向，最新的技术应用和市场资讯及时的传递给广大科技开发、科学研究、产品设计人员。本网站已成功为石油、化工、电力、医药、生物、航空、航天、国防、能源、冶金、电子、工业、农业、交通、汽车、矿山、煤炭、纺织、信息、通信、IT、安防、环保、印刷、科研、气象、仪器仪表等领域从事科学研究、产品设计、开发、生产制造的科技人员、管理人员、和采购人员提供满意服务。我们公司专业生产、代理、经销、销售各种传感器、变送器、敏感元器件、开关、执行器、仪器仪表、自动化控制系统：专业从事设计、生产、销售各种传感器、变送器、各种测控仪表、热工仪表、现场控制器、计算机控制系统、数据采集系统、各类环境监控系统、专用控制系统应用软件以及嵌入式系统开发及应用等工作。如热敏电阻、压敏电阻、温度传感器、温度变送器、湿度传感器、湿度变送器、气体传感器、气体变送器、压力传感器、压力变送、称重传感器、物（液）位传感器、物（液）位变送器、流量传感器、流量变送器、电流（压）传感器、溶氧传感器、霍尔传感器、图像传感器、超声波传感器、位移传感器、速度传感器、加速度传感器、扭距传感器、红外传感器、紫外传感器、火焰传感器、激光传感器、振动传感器、轴角传感器、光电传感器、接近传感器、干簧管传感器、继电器传感器、微型电泵、磁敏（阻）传感器、压力开关、接近开关、光电开关、色标传感器、光纤传感器、齿轮测速传感器、时间继电器、计数器、计米器、温控仪、固态继电器、调压模块、电磁铁、电压表、电流表等特殊传感器。同时承接传感器应用电路、产品设计和自动化工程项目。

更多产品请看本公司产品专用销售网站：

商斯达中国传感器科技信息网：<http://www.sensor-ic.com/>

商斯达工控安防网：<http://www.pc-ps.net/>

商斯达电子元器件网：<http://www.sunstare.com/>

商斯达微波光电产品网：[HTTP://www.rfoe.net/](http://www.rfoe.net/)

商斯达消费电子产品网：<http://www.icasic.com/>

商斯达军工产品网：<http://www.junpinic.com/>

商斯达实业科技产品网：<http://www.sunstars.cn/> 传感器销售热线：

地址：深圳市福田区福华路福庆街鸿图大厦1602室

电话：0755-83607652 83376489 83376549 83370250 83370251 82500323

传真：0755-83376182 (0) 13902971329 MSN: [SUNS888@hotmail.com](mailto:SUNS888@hotmail.com)

邮编：518033 E-mail: [szss20@163.com](mailto:szss20@163.com) QQ: 195847376

深圳赛格展销部：深圳华强北路赛格电子市场2583号 电话：0755-83665529 25059422

技术支持：0755-83394033 13501568376

欢迎索取免费详细资料、设计指南和光盘；产品凡多，未能尽录，欢迎来电查询。

北京分公司：北京海淀区知春路132号中发电子大厦3097号

TEL: 010-81159046 82615020 13501189838 FAX: 010-62543996

上海分公司：上海市北京东路668号上海赛格电子市场D125号

TEL: 021-28311762 56703037 13701955389 FAX: 021-56703037

西安分公司：西安高新开发区20所(中国电子科技集团导航技术研究所)

西安劳动南路88号电子商城二楼D23号

TEL: 029-81022619 13072977981 FAX: 029-88789382