



SMBus/I²C Compatible, 10-bit Digital Temperature Sensor in SOT-23

Preliminary Technical Data

AD7414/15

FEATURES

10-Bit Temperature to Digital Converter.

Temperature ranges:
-55 °C to +125 °C

Accuracy of ± 2 °C

SMBus™/I²C^R Compatible Serial Interface

3 μ A Power-Down Current

Temperature Conversion Time - 29 μ s typ

Space Saving 6-pin (AD7414) and
5-pin (AD7415) SOT-23 Package

Pin-Selectable Addressing via AS

Over Temperature Indicator (AD7414 only)

SMBus alert function (AD7414 only)

Four Versions Allow Eight I²C Addresses

APPLICATIONS

Hard Disk Drives

Personal Computers

Electronic Test Equipment

Office Equipment

Domestic Appliances

Process Control

Cellular Phones

GENERAL DESCRIPTION

The AD7414/15 is a complete temperature monitoring system in a 6-pin and 5-pin SOT-23 package. It contains a bandgap temperature sensor and 10-bit ADC to monitor and digitize the temperature reading to a resolution of 0.25°C.

The AD7414/15 provides a two-wire serial interface which is compatible with SMBus and I²C interfaces. The part comes in four versions, AD7414/15-0, AD7414/15-1, AD7414/15-2 and the AD7414/15-3. The AD7414/15-0 & AD7414/15-1 versions allow for the choice of three different SMBus addresses for each version. All four versions give the possibility of eight different I²C addresses for the AD7414/15.

The AD7414/15's 2.7V supply voltage, low supply current, serial interface and small package size, make it ideal for a variety of applications, including personal computers, office equipment, cellular phones and domestic appliances.

In the AD7414, on-chip registers can be programmed with high and low temperature limits, and an open drain Over-Temperature Indicator output (ALERT), which becomes active when a programmed limit is exceeded. A

FUNCTIONAL BLOCK DIAGRAMS

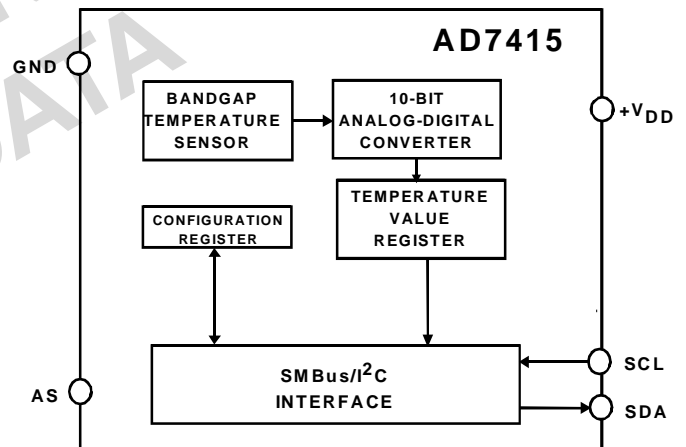
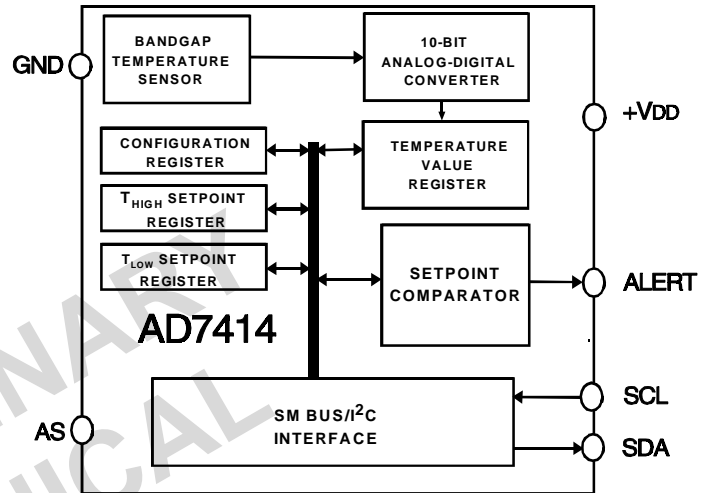

configuration register allows programming of the sense of the ALERT output (active high or active low). This output can be used as an interrupt or as an SMBus alert.

PRODUCT HIGHLIGHTS

1. The AD7414/15 has an on chip temperature sensor that allows an accurate measurement of the ambient temperature to be made. The measurable temperature range is -55°C to +125°C with a ± 2 °C temperature accuracy over the full temperature range.

(cont. on page 5)

REV. PrE 10/00

Information furnished by Analog Devices is believed to be accurate and reliable. However, no responsibility is assumed by Analog Devices for its use, nor for any infringements of patents or other rights of third parties which may result from its use. No license is granted by implication or otherwise under any patent or patent rights of Analog Devices.

SUNSTAR自动化 <http://www.sensor-ic.com/> TEL: 0755-83376489 FAX:0755-83376182 E-MAIL:szss20@163.com

SMBus is a trademark and I²C is a registered trademark of Philips Corporation

One Technology Way, P.O. Box 9106, Norwood, MA 02062-9106, U.S.A.
Tel: 781/329-4700 World Wide Web Site: <http://www.analog.com>
Fax: 781/326-8703 Analog Devices, Inc., 2000

AD7414/15-SPECIFICATIONS¹ ($T_A = T_{MIN}$ to T_{MAX} , $V_{DD} = 2.7V$ to $5.5V$, unless otherwise noted)

Parameter	A Version	Units	Test Conditions/Comments
TEMPERATURE SENSOR AND ADC			
Accuracy	±2.0	°C max	$T_A = -55^{\circ}C$ to $+125^{\circ}C$
Resolution	10	Bits	
Update Rate, t_R	800	ms typ	
Temperature Conversion Time	25	µs typ	
POWER SUPPLIES			
Supply Current ²			
Peak Supply Current ³	1.2	mA max	Peak current during conversion.
Inactive Serial Bus ⁴			
Normal Mode @ 3 V	169	µA typ	Supply Current with serial bus inactive. Part not converting and D7 of Config. Reg. = 0.
Normal Mode @ 5 V	188	µA typ	
Active Serial Bus ⁵			
Normal Mode @ 3 V	tbd	µA typ	Supply Current with serial bus active. Part not converting and D7 of Config. Reg. = 0.
Normal Mode @ 5 V	tbd	µA typ	
Shutdown Mode	3	µA max	D7 of Config. Reg. = 1. Typical values are 0.3 µA at 3 V and 0.8 µA at 5 V.
DIGITAL INPUT			
Input High Voltage, V_{IH}	2.4	V min	$V_{IN} = 0V$ to V_{DD} All Digital Inputs
Input Low Voltage, V_{IL}	0.8	V max	
Input Current, I_{IN}	±1	mA max	
Input Capacitance, C_{IN}	10	pF max	
DIGITAL OUTPUT			
Output High Voltage, V_{OH}	2.4	V min	$I_{OL} = 1.6mA$ $V_{OH} = 5V$
Output Low Voltage, V_{OL}	0.4	V max	
Output High Current, I_{OH}	1	mA max	$I_{OUT} = 4mA$
Output Capacitance, C_{OUT}	50	pF max	
ALERT Output Saturation Voltage	0.8	V max	
AC ELECTRICAL CHARACTERISTICS ⁶			
Serial Clock Period, t_1	2.5	µs min	See Figure 1
Data In Setup Time to SCL High, t_2	50	ns min	See Figure 1
Data Out Stable after SCL Low, t_3	0	ns min	See Figure 1
SDA Low Setup Time to SCL Low (Start Condition), t_4	50	ns min	See Figure 1
SDA High Hold Time after SCL High (Stop Condition), t_5	50	ns min	See Figure 1
SDA and SCL Fall Time, t_6	90	ns max	See Figure 1
Power-up Time	4	µs typ	Guaranteed by Design

Specifications subject to change without notice.

NOTES

- 1 Temperature Ranges as follows: A Version = $-55^{\circ}C$ to $+125^{\circ}C$.
- 2 These current values can be used to determine average power consumption at different oneshot conversation rates. Average power consumption at the automatic conversation rate of 1.25Hz is tbd.
- 3 This peak supply current is required for 29us (the conversion time plus power-up time) out of every 800us (the conversion rate).
- 4 These current values are derived by not issuing a stop condition at the end of a write or read, thus preventing the part from going into a conversion.
- 5 The tbdµA current is derived assuming a 400kHz serial clock being active continuously.
- 6 The SDA & SCL timing is measured with the input filters turned on so as to meet the Fast-Mode I²C specification. Switching off the input filters improves the transfer rate but has a negative affect on the EMC behaviour of the part.

Preliminary Technical Data

AD7414/15

AD7414 PIN FUNCTION DESCRIPTION

Mnemonic	Description
GND	Analog and Digital Ground.
AS	Logic Input. Address Select Input which selects one of three I ² C addresses for the AD7414/15 (See Table I).
VDD	Positive Supply Voltage, +2.7V to +5.5 V.
SCL	Digital Input. Serial Bus Clock.
ALERT	AD7414 Digital Output. Over Temperature Indicator, becomes active when temperature exceeds T _{HIGH} . Open-drain output.
SDA	Digital I/O. Serial Bus Bi-directional Data. Open-drain output.

PIN CONFIGURATIONS

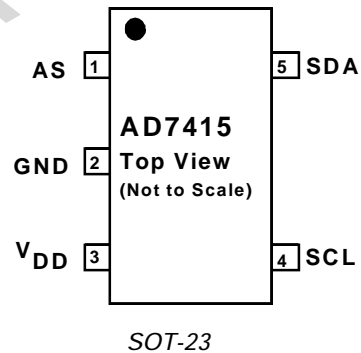
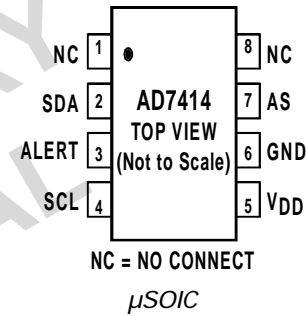
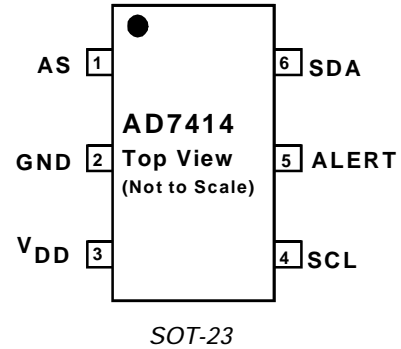

ABSOLUTE MAXIMUM RATINGS*

(T_A = +25°C unless otherwise noted)

V _{DD} to GND.....	-0.3 V to +7 V
SDA Input Voltage to GND.....	-0.3 V to +7 V
SDA Output Voltage to GND.....	-0.3 V to +7 V
SCL Input Voltage to GND.....	-0.3 V to +7 V
ALERT Output Voltage to GND.....	-0.3 V to +7 V
Operating Temperature Range	-55°C to +150°C
Storage Temperature Range	-65°C to +150°C
Junction Temperature	+150°C
SOT-23, Power Dissipation	450 mW
θ _{JA} Thermal Impedance	240°C/W
Lead Temperature, Soldering	
Vapor Phase (60 sec)	+215°C
Infrared (15 sec)	+220°C

*Stresses above those listed under Absolute Maximum Ratings may cause permanent damage to the device. This is a stress rating only; functional operation of the device at these or any other conditions above those indicated in the operational section of this specification is not implied. Exposure to absolute maximum rating conditions for extended periods may affect device reliability.

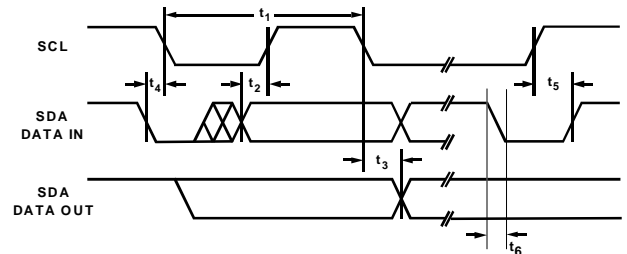

Figure 1. Diagram for Serial Bus Timing

CAUTION

ESD (electrostatic discharge) sensitive device. Electrostatic charges as high as 4000 V readily accumulate on the human body and test equipment and can discharge without detection. Although the AD7414/15 features proprietary ESD protection circuitry, permanent damage may occur on devices subjected to high energy electrostatic discharges. Therefore, proper ESD precautions are recommended to avoid performance degradation or loss of functionality.



AD7414/15

Preliminary Technical Data

ORDERING GUIDE

Model	Temperature Range	Temperature Error	Package Description	Branding Information	Min Qty's/ Reel
AD7414ART-0REEL7	-55°C to +125°C	±2°C	6-Pin SOT-23	CHA ¹	3000
AD7414ART-0REEL	-55°C to +125°C	±2°C	6-Pin SOT-23	CHA ¹	10000
AD7414ARM-0REEL7	-55°C to +125°C	±2°C	8-Pin μ-SOIC	CHA ¹	3000
AD7414ARM-0REEL	-55°C to +125°C	±2°C	8-Pin μ-SOIC	CHA ¹	10000
AD7414ART-1REEL7	-55°C to +125°C	±2°C	6-Pin SOT-23	CHB ¹	3000
AD7414ART-1REEL	-55°C to +125°C	±2°C	6-Pin SOT-23	CHB ¹	10000
AD7414ARM-1REEL7	-55°C to +125°C	±2°C	8-Pin μ-SOIC	CHB ¹	3000
AD7414ARM-1REEL	-55°C to +125°C	±2°C	8-Pin μ-SOIC	CHB ¹	10000
AD7414ART-2REEL7	-55°C to +125°C	±2°C	6-Pin SOT-23	CHC ²	3000
AD7414ART-2REEL	-55°C to +125°C	±2°C	6-Pin SOT-23	CHC ²	10000
AD7414ARM-2REEL7	-55°C to +125°C	±2°C	8-Pin μ-SOIC	CHC ²	3000
AD7414ARM-2REEL	-55°C to +125°C	±2°C	8-Pin μ-SOIC	CHC ²	10000
AD7414ART-3REEL7	-55°C to +125°C	±2°C	6-Pin SOT-23	CHD ²	3000
AD7414ART-3REEL	-55°C to +125°C	±2°C	6-Pin SOT-23	CHD ²	10000
AD7414ARM-3REEL7	-55°C to +125°C	±2°C	8-Pin μ-SOIC	CHD ²	3000
AD7414ARM-3REEL	-55°C to +125°C	±2°C	8-Pin μ-SOIC	CHD ²	10000
AD7415ART-0REEL7	-55°C to +125°C	±2°C	5-Pin SOT-23	CGA ¹	3000
AD7415ART-0REEL	-55°C to +125°C	±2°C	5-Pin SOT-23	CGA ¹	10000
AD7415ART-1REEL7	-55°C to +125°C	±2°C	5-Pin SOT-23	CGB ¹	3000
AD7415ART-1REEL	-55°C to +125°C	±2°C	5-Pin SOT-23	CGB ¹	10000
AD7415ART-2REEL7	-55°C to +125°C	±2°C	5-Pin SOT-23	CGC ²	3000
AD7415ART-2REEL	-55°C to +125°C	±2°C	5-Pin SOT-23	CGC ²	10000
AD7415ART-3REEL7	-55°C to +125°C	±2°C	5-Pin SOT-23	CGD ²	3000
AD7415ART-3REEL	-55°C to +125°C	±2°C	5-Pin SOT-23	CGD ²	10000

Notes:-

1. Available to order.
2. Contact factory for availability.

Preliminary Technical Data

AD7414/15

PRODUCT HIGHLIGHTS (cont. from page 1)

2. SMBus/I²C Compatible Serial Interface with pin selectable choice of three addresses per version of the AD7414/15, eight address options in total.
3. Supply voltage of 2.7V to 5.5V.
4. Space saving 5-Pin and 6-Pin SOT-23 package.
5. 10-bit temperature reading to 0.25°C resolution.
6. The AD7414 has an Over Temperature Indicator which can be software disabled. Used as an interrupt of SMBus alert.
7. Oneshot and automatic temperature conversation rates.

Table 1. I²C Address Selection

Part Number	AS Pin	I ² C Address
AD7414-0	Float	1001 000
AD7414-0	GND	1001 001
AD7414-0	VDD	1001 010
AD7414-1	Float	1001 100
AD7414-1	GND	1001 101
AD7414-1	VDD	1001 110
AD7414-2	N/A	1001 011
AD7414-3	N/A	1001 111
AD7415-0	Float	1001 000
AD7415-0	GND	1001 001
AD7415-0	VDD	1001 010
AD7415-1	Float	1001 100
AD7415-1	GND	1001 101
AD7415-1	VDD	1001 110
AD7415-2	N/A	1001 011
AD7415-3	N/A	1001 111

AD7414/15

Preliminary Technical Data

CIRCUIT INFORMATION

The AD7414/15 is a stand alone digital temperature sensor. The on-chip temperature sensor allows an accurate measurement of the ambient device temperature to be made. The 10-bit A/D converter converts the temperature measured into a two's complement format for storage in the Temperature Register. The A/D converter is made up of a conventional successive-approximation converter based around a capacitor DAC. The serial interface is I²C and SMBus compatible. The AD7414/15 requires a 2.7 V to 5.5 V power supply. The temperature sensor has a working measurement range of -55 °C to +125 °C.

FUNCTIONAL DESCRIPTION

Temperature measurement is initiated by a couple of methods. The first method uses an internal clock count-down of 800ms and then a conversion is performed. The internal oscillator is the only circuit that's powered up between conversions and once it times out, every 800ms, a wake-up signal is sent to power-up the rest of the circuitry. A monostable is activated at the beginning of the wake-up signal to ensure that sufficient time is given to the power-up process. The monostable typically takes 4 μs to time out. It then takes typically 25μs for each conversion to be completed. The new temperature value is loaded into the Temperature Value Register and ready for reading by the I²C interface.

A temperature measurement is also initiated everytime the oneshot method is used. This method requires the user to write to the Oneshot bit in the Configuration Register when a temperature measurement is needed. Setting the Oneshot bit to a 1 will start a temperature conversion directly after the write operation. The track/hold goes into hold approximately 4μs (monostable time-out) after the STOP condition and a conversion is then initiated. Typically 25μs later the conversion is complete and the Temperature Value Register is loaded with a new temperature value.

The measurement modes are compared with a high temperature limit, stored in an 8-bit read/write register. This is applicable to only the AD7414 as the AD7415 does not have an ALERT pin and subsequently does not have an over-temperature monitoring function. If the measurement is greater than the high limit, the ALERT pin is activated (if it has already been enabled in the Configuration Register). There are two ways to deactivate the ALERT pin again, firstly when the Alert Reset bit in the Configuration register is set to a 1 by a write operation and secondly when the temperature measured is less than the value in the T_{LOW} Register. This ALERT pin is compatible with the SMBus SMBALERT option.

Configuration functions consist of:

- switching between normal operation and full power-down.
- enabling or disabling the SCL and SDA filters.
- enabling or disabling the ALERT function.
- setting ALERT pin polarity.

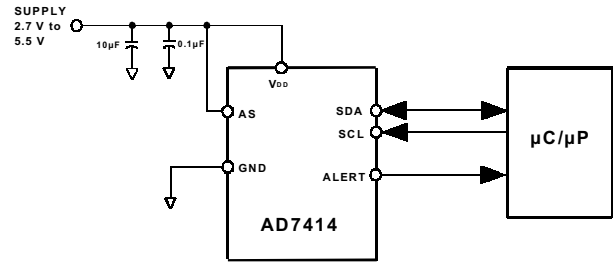

Figure 2. Typical Connection Diagram

MEASUREMENT TECHNIQUE

A common method of measuring temperature is to exploit the negative temperature coefficient of a diode, or the base-emitter voltage of a transistor, operated at constant current. Unfortunately, this technique requires calibration to null out the effect of the absolute value of V_{BE} , which varies from device to device.

The technique used in the AD7414/15 is to measure the change in V_{BE} when the device is operated at two different currents.

This is given by:

$$\Delta V_{BE} = KT/q \times \ln(N)$$

where:

K is Boltzmann's constant

q is charge on the electron (1.6×10^{-19} Coulombs).

T is absolute temperature in Kelvins.

N is the ratio of the two currents.

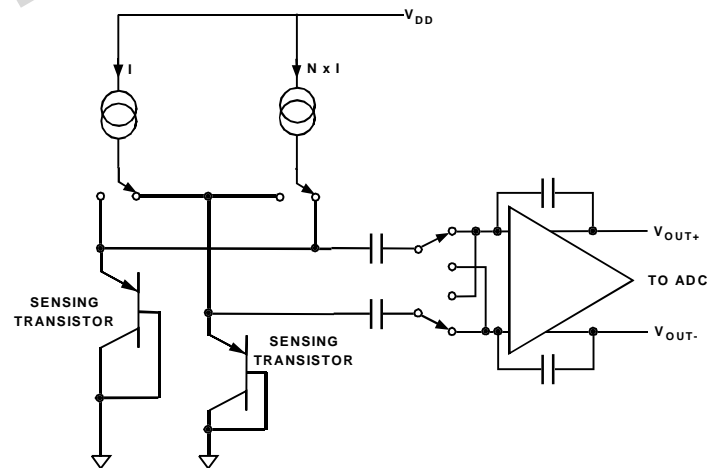

Figure 3. Temperature Measurement Technique

Figure 3 shows the method the AD7414/15 uses to measure the ambient device temperature. To measure ΔV_{BE} , the sensor (substrate transistor) is switched between operating currents of I and $N \times I$. The resulting waveform is passed through a chopper-stabilized amplifier that performs the functions of amplification and rectification of the waveform to produce a dc voltage proportional to ΔV_{BE} . This voltage is measured by the ADC to give a temperature output in 10-bit two's complement format.

Preliminary Technical Data

AD7414/15

TEMPERATURE DATA FORMAT

The temperature resolution of the ADC is 0.25°C which corresponds to one LSB of the ADC. The ADC can theoretically measure a temperature span of 255°C; the practical lowest value is limited to -55°C due to device maximum ratings. The A grade can measure a temperature range of -55°C to +125°C (temperature data format is shown in Table 2).

Table 2. A-Grade Temperature Data Format

Temperature	Digital Output DB9.....DB0
-55 °C	11 0010 0100
-50 °C	11 0011 1000
-25 °C	11 1001 1100
-0.25 °C	11 1111 1111
0 °C	00 0000 0000
+0.25 °C	00 0000 0001
+10 °C	00 0010 1000
+25 °C	00 0110 0100
+50 °C	00 1100 1000
+75 °C	01 0010 1100
+100 °C	01 1001 0000
+125 °C	01 1111 0100

A-Grade Temperature Conversion Formula :-

(1) Positive Temperature = ADC Code/4

(2) Negative Temperature = (ADC Code* - 512)/4

*DB9 is removed from the ADC Code.

INTERNAL REGISTER STRUCTURE

The AD7414 has five internal registers as shown in Figure 4. Four are data registers and one is an address pointer register.

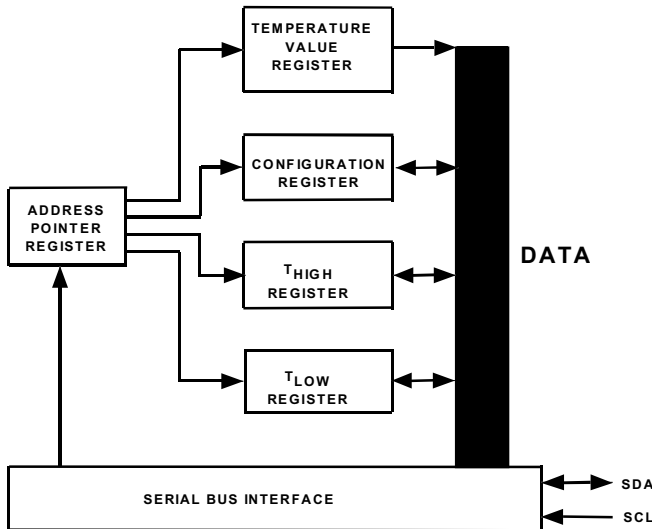

Figure 4. AD7414 Register Structure

The AD7415 has three internal registers as shown in Figure 5. Two are data registers and one is an address pointer register.

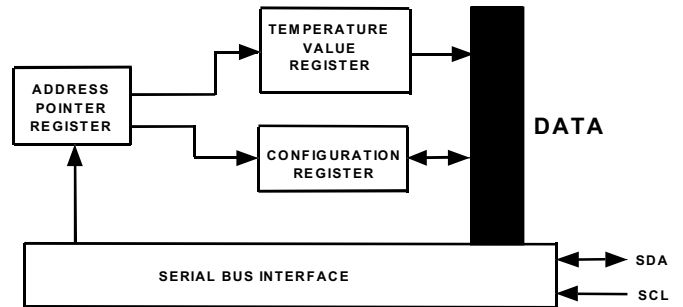

Figure 5. AD7415 Register Structure

Each data register has an address which is pointed to by the Address Pointer register when communicating with it. The Temperature Value register is the only data register that is read only.

ADDRESS POINTER REGISTER

The Address Pointer Register is an 8-bit register which stores an address that points to one of the four data registers of the AD7414 and one of the two data registers of the AD7415. The first byte of every serial write operation to the AD7414/15 is the address of one of the data registers, which is stored in the Address Pointer Register, and selects the data register to which subsequent data bytes are written. Only the two LSBs of this register are used to select a data register.

Table 4. Address Pointer Register

P7*	P6*	P5*	P4*	P3*	P2*	P1	P0
0	0	0	0	0	0	Register Select	

Table 5. AD7414 Register Address

P1	P0	Registers
0	0	Temperature Value Register (Read only)
0	1	Configuration Register (Read/Write)
1	0	T _{HIGH} Register (Read/Write)
1	1	T _{LOW} Register (Read/Write)

Table 6. AD7415 Register Address

P1	P0	Registers
0	0	Temperature Value Register (Read Only)
0	1	Configuration Register (Read/Write)

AD7414/15

Preliminary Technical Data

CONFIGURATION REGISTER (Address 01H)

The Configuration Register is an 8-bit read/write register that is used to set the operating modes of the AD7414/15. In the AD7414, six of the MSBs are used (D7 to D2) to set the operating modes, see Table 8. D0 and D1 are used for factory settings and must have zeros written to them during normal operation.

Table 7. AD7414 Configuration Register

D7	D6	D5	D4	D3	D2	D1	D0
PD	FLTR	ALERT $\overline{\text{EN}}$	ALERT POLARITY	ALERT RESET	ONE- SHOT	TEST MODE	
0*	1*	0*	0*	0*	0*	0's*	

*Default settings at Power-up.

Table 8. AD7414 Configuration Register Settings

D7	Full Power-down if = 1
D6	Bypass SDA & SCL filtering if = 0
D5	Disable ALERT if = 1
D4	ALERT is active low if D4 = 0, ALERT is active high if D4 = 1
D3	Reset the Alert pin if set to 1. The next temperature conversion will have the ability to activate the Alert function. The bit status is not stored, thus this bit will be "0" if read.
D2	Initiate a temperature conversion if set to a 1. The bit status is not stored, thus this bit will be "0" if read.

In the AD7415, only three of the bits are used (D7, D6 and D2) to set the operating modes, see Table 10. D0, D1 and D3 to D5 are used for factory settings and must have zeros written to them during normal operation.

Table 9. AD7415 Configuration Register

D7	D6	D5	D4	D3	D2	D1	D0
PD	FLTR	TESTMODE		ONE SHOT	TEST MODE		
0*	1*	0's*		0's*	0's*		

*Default settings at Power-up.

Table 10. AD7415 Configuration Register Settings

D7	Full Power-down if = 1
D6	Bypass SDA & SCL filtering if = 0
D2	Initiate a temperature conversion if set to a 1. The bit status is not stored, thus this bit will be "0" if read.

If the AD7414/15 is in powerdown mode (D7 = 1), a temperature conversion can still be initiated by the oneshot operation. This involves a write operation to the Configuration register and setting the Oneshot bit to a 1 (D2 = 1) will cause the AD7414/15 to power-up, perform a single conversion and powerdown again. This is a very power efficient mode.

TEMPERATURE VALUE REGISTER(Address 00h)

The Temperature Value Register is a 10-bit read-only register which stores the temperature reading from the ADC in twos complement format. Two reads are necessary to read data from this register. Table 11 shows the contents of the first byte to be read while Table 12 and Table 13 show the contents of the second byte to be read from AD7414 and AD7415 respectively. In Table 12, D3 to D5 of the second byte are used as flag bits and are obtained from other internal registers. They function as follows :-

ALERT_Flag : the state of this bit is same as that of the ALERT pin.

T_{HIGH}_Flag : this flag is set to a 1 when the temperature measured goes above the T_{HIGH} limit. It is reset when the 2nd temperature byte (Table 12) is read. If the temperature is still greater than the T_{HIGH} limit after the read operation, then the flag will be set again.

T_{LOW}_Flag : this flag is set to a 1 when the temperature measured goes below the T_{LOW} limit. It is reset when the 2nd temperature byte (Table 12) is read. If the temperature is still less than the T_{LOW} limit after the read operation, then the flag will be set again.

The full theoretical span of the ADC is 255°C, but in practice the temperature measurement range is limited to the operating range of the device, -55°C to +125°C for A-grade and -55°C to +135°C for S-grade.

Table 11. Temperature Value Register (First Read)

D15	D14	D13	D12	D11	D10	D9	D8
MSB	B8	B7	B6	B5	B4	B3	B2

Table 12. AD7414 Temperature Value Register (Second Read)

D7	D6	D5	D4	D3	D2	D1	D0
B1	LSB	ALERT Flag	T _{HIGH} Flag	T _{LOW} Flag	0	0	0

Table 13. AD7415 Temperature Value Register (Second Read)

D7	D6	D5	D4	D3	D2	D1	D0
B1	LSB	N/A	N/A	N/A	N/A	N/A	N/A

Preliminary Technical Data

AD7414/15

AD7414 T_{HIGH} REGISTER(Address 02h)

The T_{HIGH} Register is an 8-bit read/write register which stores the upper limit that will activate the ALERT output. Therefore if the value in the Temperature Value Register is greater than the value in the T_{HIGH} Register, then the ALERT pin is activated (that is if ALERT is enabled in the Configuration Register). As it is an 8-bit register the temperature resolution is 1°C.

Table 14. T_{HIGH} Register

D7	D6	D5	D4	D3	D2	D1	D0
MSB	B6	B5	B4	B3	B2	B1	B0

AD7414 T_{LOW} REGISTER(Address 03h)

The T_{LOW} Register is an 8-bit read/write register which stores the lower limit that will deactivate the ALERT output. Therefore if the value in the Temperature Value Register is less than the value in the T_{LOW} Register, the ALERT pin is deactivated (that is if ALERT is enabled in the Configuration Register). As it is an 8-bit register the temperature resolution is 1°C.

Table 15. T_{LOW} Register

D7	D6	D5	D4	D3	D2	D1	D0
MSB	B6	B5	B4	B3	B2	B1	B0

AD7414/15 SERIAL INTERFACE

Control of the AD7414/15 is carried out via the I²C-compatible serial bus. The AD7414/15 is connected to this bus as a slave device, under the control of a master device, e.g. the processor.

SERIAL BUS ADDRESS

Like all I²C-compatible devices, the AD7414/15 has a 7-bit serial address. The four MSBs of this address for the AD7414/15 are set to 1001. The AD7414/15 comes in four versions, the AD7414/15-0, AD7414/15-1, AD7414/15-2 and the AD7414/15-3. The first two versions have three different I²C addresses available which are selected by either tying the AS pin to GND, to VDD or letting the pin float (see Table 1). By giving different addresses for

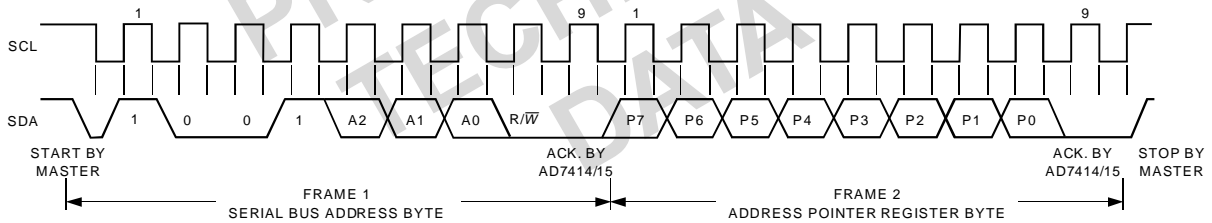

Figure 5. Writing to the Address Pointer Register to select a register for a subsequent Read operation

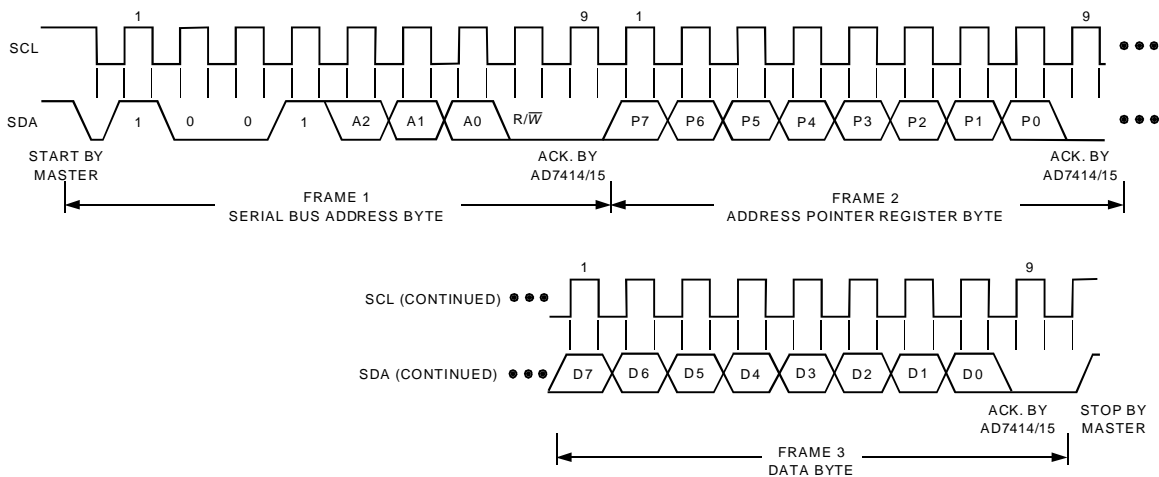

Figure 6. Writing to the Address Pointer Register followed by a single byte of data to the selected register

AD7414/15

Preliminary Technical Data

the four versions, up to eight AD7414/15's can be connected to a single, serial bus, or the addresses can be set to avoid conflicts with other devices on the bus.

The serial bus protocol operates as follows:

1. The master initiates data transfer by establishing a START condition, defined as a high to low transition on the serial data line SDA whilst the serial clock line SCL remains high. This indicates that an address/data stream will follow. All slave peripherals connected to the serial bus respond to the START condition, and shift in the next 8 bits, consisting of a 7-bit address (MSB first) plus a R/W bit, which determines the direction of the data transfer, i.e. whether data will be written to or read from the slave device.

The peripheral whose address corresponds to the transmitted address responds by pulling the data line low during the low period before the ninth clock pulse, known as the Acknowledge Bit. All other devices on the

bus now remain idle whilst the selected device waits for data to be read from or written to it. If the R/W bit is a 0 then the master will write to the slave device. If the R/W bit is a 1 the master will read from the slave device.

2. Data is sent over the serial bus in sequences of 9 clock pulses, 8 bits of data followed by an Acknowledge Bit from the receiver of data. Transitions on the data line must occur during the low period of the clock signal and remain stable during the high period, as a low to high transition when the clock is high may be interpreted as a STOP signal.
3. When all data bytes have been read or written, stop conditions are established. In WRITE mode, the master will pull the data line high during the 10th clock pulse to assert a STOP condition. In READ mode, the master device will pull the data line high during the low period before the 9th clock pulse. This is known as No

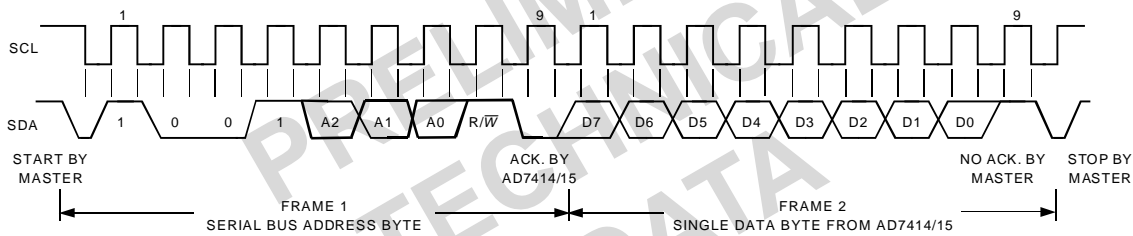

Figure 7. Reading a single byte of data from a selected register

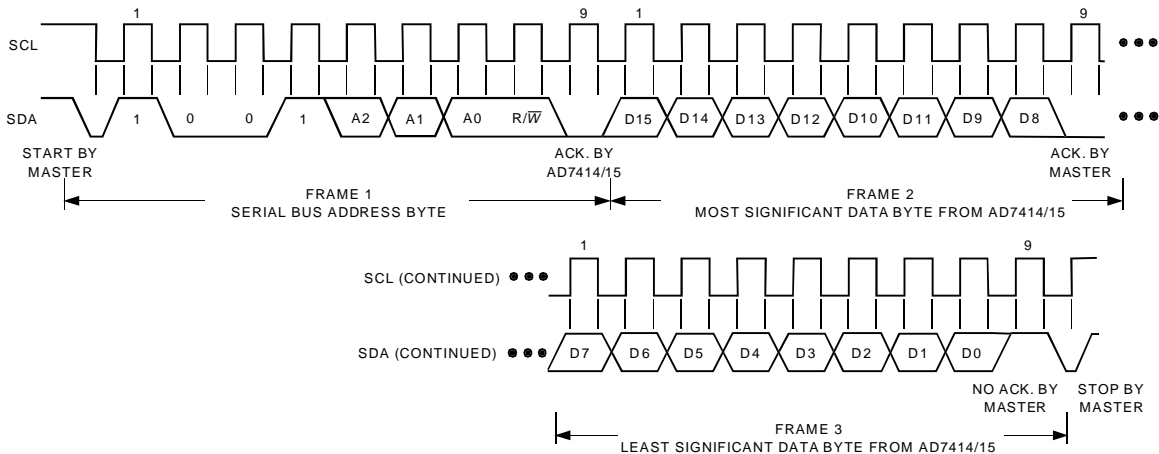

Figure 8. Reading two bytes of data from the Temperature Value Register

Preliminary Technical Data

AD7414/15

Acknowledge. The master will then take the data line low during the low period before the 10th clock pulse, then high during the 10th clock pulse to assert a STOP condition.

Any number of bytes of data may be transferred over the serial bus in one operation, but it is not possible to mix read and write in one operation, because the type of operation is determined at the beginning and cannot subsequently be changed without starting a new operation.

WRITING TO THE AD7414/15

Depending on the register being written to, there are two different writes for the AD7414/15.

Writing to the Address Pointer Register for a subsequent read.

In order to read data from a particular register, the Address Pointer Register must contain the address of that register. If it does not, the correct address must be written to the Address Pointer Register by performing a single-byte write operation, as shown in Figure 5. The write operation consists of the serial bus address followed by the address pointer byte. No data is written to any of the data registers. A read operation is then performed to read the register.

Writing a single byte of data to the Configuration Register, T_{HIGH} Register or T_{LOW} Register.

All three registers are 8-bit registers so only one byte of data can be written to each register. Writing a single byte of data to one of these registers consists of the serial bus address, the data register address written to the Address Pointer Register, followed by the data byte written to the selected data register. This is illustrated in Figure 6.

READING DATA FROM THE AD7414/15

Reading data from the AD7414/15 is a one or two byte operation. Reading back the contents of the Configuration Register, T_{HIGH} Register or T_{LOW} Register is a single byte read operation as shown in Figure 7. The register address previously having been set up by a single byte write operation to the Address Pointer Register. Once the register address has been set up, any number of reads can be subsequently done from that register without having to write to the Address Pointer Register again. If you want to read from another register then you will have to write to the Address Pointer Register again to set up the relevant register address.

Reading data from the Temperature Value Register is a two byte operation as shown in Figure 8. The same rules apply for a two byte read as a single byte read.

SMBUS ALERT

The AD7414 ALERT output is an SMBus interrupt line for devices that want to trade their ability to master for an extra pin. The AD7414 is a slave only device and uses the SMBUS ALERT to signal the host device that it wants to talk. The SMBUS ALERT on the AD7414 is used as an over temperature indicator.

The ALERT pin has an open-drain configuration which allows the ALERT outputs of several AD7414's to be wired-AND together when the ALERT pin is active low.

Use D4 of the Configuration Register to set the active polarity of the ALERT output. The power-up default is active low. The ALERT function can be disabled or enabled by setting D5 of the Configuration Register to 1 or 0 respectively.

The host device can process the ALERT interrupt and simultaneously access all SMBUS ALERT devices through the alert response address. Only the device which pulled the ALERT low will acknowledge the ARA (Alert Response Address). If more than one device pulls the ALERT pin low, the highest priority (lowest address) device will win communication rights via standard I²C arbitration during the slave address transfer.

The ALERT output becomes active when the value in the Temperature Value Register exceeds the value in the T_{HIGH} Register. It is reset when a write operation to the Configuration register sets D3 to a 1 or when the temperature falls below the value stored in the T_{LOW} Register.

The ALERT output requires an external pull-up resistor. This can be connected to a voltage different from V_{DD} provided the maximum voltage rating of the ALERT output pin is not exceeded. The value of the pull-up resistor depends on the application, but should be as large as possible to avoid excessive sink currents at the ALERT output, which can heat the chip and affect the temperature reading.

POWER-ON DEFAULTS

The AD7414/15 always powers up with the following defaults.....

Address Pointer Register pointing to the Temperature Value Register.

T_{HIGH} Register loaded with 7F Hex.

T_{LOW} Register loaded with 80 Hex.

Configuration Register loaded with 40 Hex.

Note: The AD7415 does not have any T_{HIGH} or T_{LOW} registers.

OPERATING MODES

Mode 1

This is the power-on default mode of the AD7414/15. In this mode the AD7414/15 does a temperature conversion every 800ms and then partially powers down until the next conversion occurs.

If a oneshot operation (setting D2 of the Configuration register to a 1) is performed between automatic conversions, a conversion is initiated right after the write operation. After this conversion, the part returns to performing a conversion every 800ms.

Depending on where a serial port access occurs during a conversion, that conversion might or might not be aborted. If the conversion is completed before the part recognizes a serial port access then the Temperature Register will be updated with the new conversion. If the conversion is completed after the part recognizes a serial port access then the internal logic will prevent the Temperature Register from being updated as corrupt data could be read.

AD7414/15

Preliminary Technical Data

A temperature conversion can start anytime during a serial port access (other than a oneshot operation), but the result of that conversion will only be loaded into the Temperature Register if serial port access is not active at the end of the conversion.

Mode 2

The only other mode the AD7414/15 operates in, is the full power-down mode. This mode is usually used when temperature measurements are required at a very slow rate. The power consumption of the part can be greatly reduced in this mode by writing to the part to go to a full power-down. Full power-down is initiated right after D7 of the Configuration Register set to a 1.

When a temperature measurement is required, a write operation can be performed to power-up the part and put it into oneshot mode (setting D2 of the Configuration register to a 1). The power-up takes approximately 4 μ s. The part then performs a conversion and is returned to full power-down. The temperature value can be read in the full power-down mode as the serial interface is still powered up.

POWER vs. THROUGHPUT

The two modes of operation for the AD7414/15 will produce different power versus throughput performances. Mode 2 is the sleep mode of the part and it achieves the optimum power performance.

Mode 1

In this mode continuous conversions are performed at a rate of approximately one every 800ms. Figure 9 shows the times and the currents involved with this mode of operation for a 5 V supply. At 5 V the current consumption for the part when converting is 1.1mA typically and the quiescent current is 188 μ A typically. The conversion time of 25 μ s plus power-up time of typically 4 μ s contributes 199.3nW to the overall power dissipation in the following way:

$$(29\mu\text{s}/800\text{ms}) \times (5 \text{ V} \times 1.1\text{mA}) = 199.3 \text{ nW}$$

The contribution to the total power dissipated by the remaining time is 939.96 μ W.

$$(799.971\text{ms}/800\text{ms}) \times (5 \text{ V} \times 188\mu\text{A}) = 939.96 \mu\text{W}$$

Thus the total power dissipated during each cycle is:

$$199.3 \text{ nW} + 939.96 \mu\text{W} = 940.16 \mu\text{W}$$

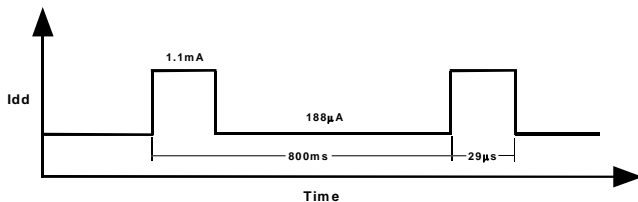

Figure 9. Mode 1 Power Dissipation

Mode 2

In this mode the part is totally powered down. All circuitry except the serial interface is switched off. The most

power efficient way of operating in this mode is to use the oneshot method. Write to the configuration register and set the oneshot bit to a 1. The part will power-up in approximately 4 μ s and then perform a conversion. Once the conversion is finished the device will power down again until the PD bit in the configuration register is set to a 0 or the oneshot bit is set to a 1. Figure 10 shows the same timing as figure 9 in mode 1, a oneshot is initiated every 800ms. If we take the voltage supply to be 5 V we can work out the power dissipation in the following way. The current consumption for the part when converting is 1.1mA typically and the quiescent current is 800nA typically. The conversion time of 25 μ s plus power-up time of typically 4 μ s contributes 199.3 nW to the overall power dissipation in the following way:

$$(29\mu\text{s}/800\text{ms}) \times (5 \text{ V} \times 1.1\text{mA}) = 199.3 \text{ nW}$$

The contribution to the total power dissipated by the remaining time is 3.9 μ W.

$$(799.971\text{ms}/800\text{ms}) \times (5 \text{ V} \times 800\text{nA}) = 3.9 \mu\text{W}$$

Thus the total power dissipated during each cycle is:

$$199.3 \text{ nW} + 3.9 \mu\text{W} = 4.1 \mu\text{W}$$

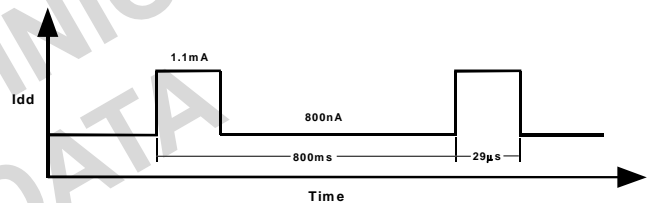

Figure 10. Mode 2 Power Dissipation

Preliminary Technical Data

AD7414/15

OUTLINE DIMENSIONS

Dimensions shown in inches and (mm).

6-LEAD PLASTIC SURFACE MOUNT SOT-23

(RT-6)

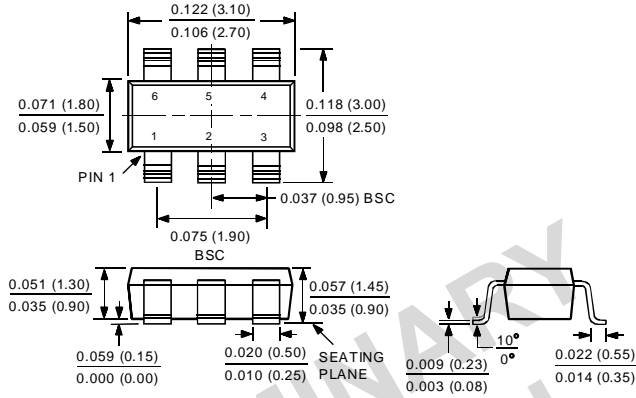

8-LEAD MINI/MICRO SOIC

(RM-8)

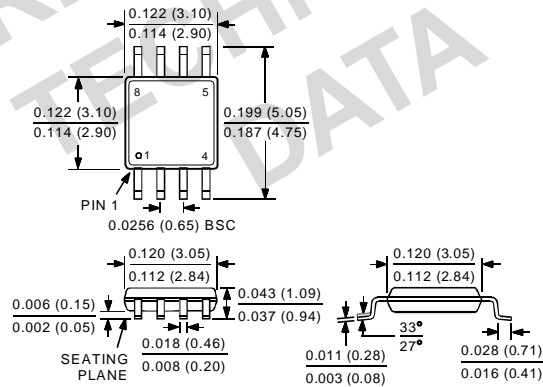

5-LEAD PLASTIC SURFACE MOUNT SOT-23

(RT-5)

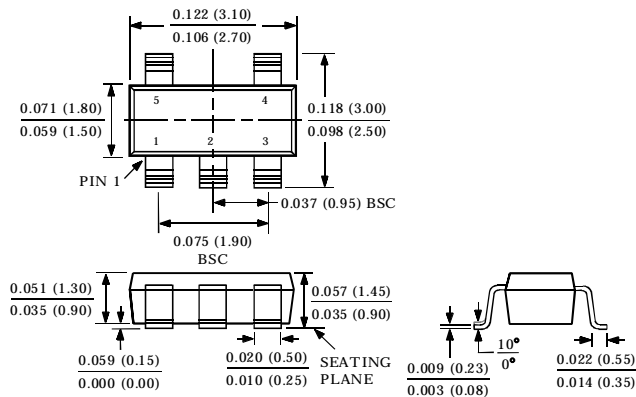

SUNSTAR商斯达实业集团是集研发、生产、工程、销售、代理经销、技术咨询、信息服务等为一体的高科技企业，是专业高科技电子产品生产厂家，是具有10多年历史的专业电子元器件供应商，是中国最早和最大的仓储式连锁规模经营大型综合电子零部件代理分销商之一，是一家专业代理和分销世界各大品牌IC芯片和电子元器件的连锁经营综合性国际公司。在香港、北京、深圳、上海、西安、成都等全国主要电子市场设有直属分公司和产品展示展销窗口门市部专卖店及代理分销商，已在全国范围内建成强大统一的供货和代理分销网络。我们专业代理经销、开发生产电子元器件、集成电路、传感器、微波光电元器件、工控机/DOC/DOM电子盘、专用电路、单片机开发、MCU/DSP/ARM/FPGA软件硬件、二极管、三极管、模块等，是您可靠的一站式现货配套供应商、方案提供商、部件功能模块开发配套商。专业以现代信息产业（计算机、通讯及传感器）三大支柱之一的传感器为主营业务，专业经营各类传感器的代理、销售生产、网络信息、科技图书资料及配套产品设计、工程开发。我们的专业网站——中国传感器科技信息网（全球传感器数据库）www.SENSOR-IC.COM 服务于全球高科技生产商及贸易商，为企业科技产品开发提供技术交流平台。欢迎各厂商互通有无、交换信息、交换链接、发布寻求代理信息。欢迎国外高科技传感器、变送器、执行器、自动控制产品厂商介绍产品到中国，共同开拓市场。本网站是关于各种传感器-变送器-仪器仪表及工业自动化大型专业网站，深入到工业控制、系统工程计 测量、自动化、安防报警、消费电子等众多领域，把最新的传感器-变送器-仪器仪表买卖信息，最新技术供求，最新采购商，行业动态，发展方向，最新的技术应用和市场资讯及时的传递给广大科技开发、科学研究、产品设计人员。本网站已成功为石油、化工、电力、医药、生物、航空、航天、国防、能源、冶金、电子、工业、农业、交通、汽车、矿山、煤炭、纺织、信息、通信、IT、安防、环保、印刷、科研、气象、仪器仪表等领域从事科学研究、产品设计、开发、生产制造的科技人员、管理人员、和采购人员提供满意服务。我们公司专业生产、代理、经销、销售各种传感器、变送器、敏感元器件、开关、执行器、仪器仪表、自动化控制系统：专门从事设计、生产、销售各种传感器、变送器、各种测控仪表、热工仪表、现场控制器、计算机控制系统、数据采集系统、各类环境监控系统、专用控制系统应用软件以及嵌入式系统开发及应用等工作。如热敏电阻、压敏电阻、温度传感器、温度变送器、湿度传感器、湿度变送器、气体传感器、气体变送器、压力传感器、压力变送、称重传感器、物（液）位传感器、物（液）位变送器、流量传感器、流量变送器、电流（压）传感器、溶氧传感器、霍尔传感器、图像传感器、超声波传感器、位移传感器、速度传感器、加速度传感器、扭距传感器、红外传感器、紫外传感器、火焰传感器、激光传感器、振动传感器、轴角传感器、光电传感器、接近传感器、干簧管传感器、继电器传感器、微型电泵、磁敏（阻）传感器、压力开关、接近开关、光电开关、色标传感器、光纤传感器、齿轮测速传感器、时间继电器、计数器、计米器、温控仪、固态继电器、调压模块、电磁铁、电压表、电流表等特殊传感器。同时承接传感器应用电路、产品设计和自动化工程项目。

更多产品请看本公司产品专用销售网站：

商斯达中国传感器科技信息网：<http://www.sensor-ic.com/>

商斯达工控安防网：<http://www.pc-ps.net/>

商斯达电子元器件网：<http://www.sunstare.com/>

商斯达微波光电产品网：[HTTP://www.rfoe.net/](http://www.rfoe.net/)

商斯达消费电子产品网：<http://www.icasic.com/>

商斯达军工产品网：<http://www.junpinic.com/>

商斯达实业科技产品网：<http://www.sunstars.cn/> 传感器销售热线：

地址：深圳市福田区福华路福庆街鸿图大厦1602室

电话：0755-83607652 83376489 83376549 83370250 83370251 82500323

传真：0755-83376182 (0) 13902971329 MSN: SUNS888@hotmail.com

邮编：518033 E-mail: szss20@163.com QQ: 195847376

深圳赛格展销部：深圳华强北路赛格电子市场2583号 电话：0755-83665529 25059422

技术支持：0755-83394033 13501568376

欢迎索取免费详细资料、设计指南和光盘；产品凡多，未能尽录，欢迎来电查询。

北京分公司：北京海淀区知春路132号中发电子大厦3097号

TEL: 010-81159046 82615020 13501189838 FAX: 010-62543996

上海分公司：上海市北京东路668号上海赛格电子市场D125号

TEL: 021-28311762 56703037 13701955389 FAX: 021-56703037

西安分公司：西安高新开发区20所(中国电子科技集团导航技术研究所)

西安劳动南路88号电子商城二楼D23号

TEL: 029-81022619 13072977981 FAX: 029-88789382